

Installation & Owner's Manual



MRCOOL®

COMFORT MADE SIMPLE

PRODIRECT™ SERIES Air Handler HAH140*C

Due to updates and constantly improving performance, the information and instructions within this manual are subject to change without notice. Please visit www.mrcool.com/documentation to ensure you have the latest version of this manual.

Version Date: 2-22-21

Thank you for choosing MRCOOL. Please read this manual carefully before installation and keep it for future reference.

Copyright © 2021 MRCOOL, LLC

**RECOGNIZE THIS SYMBOL AS AN INDICATION OF IMPORTANT SAFETY INFORMATION****! WARNING**

These instructions are intended as an aid for qualified, licensed service personnel for proper installation, adjustment, and operation of this unit. Read these instructions thoroughly before attempting installation or operation. Failure to follow these instructions may result in improper installation, adjustment, service or maintenance possibly resulting in fire, electrical shock, property damage, personal injury or death.

**DO NOT DESTROY THIS MANUAL****Please read carefully and keep in a safe place for future reference by a serviceman.**

INSTALLATION AND OWNER'S MANUAL

INDOOR SPLIT-SYSTEM UNIT MODELS: UP TO 18 SEER 1.5 TO 5 TONS

Table of Contents

1	SAFETY	2
2	GENERAL	4
3	UNIT DIMENSIONS	5
4	VERTICAL UPFLOW	6
5	VERTICAL DOWNFLOW	6
6	HORIZONTAL	7
7	ELECTRICAL WIRING	9
8	POWER WIRING	9
9	CONTROL WIRING	9
10	GROUNDING	9
11	ELECTRICAL DATA	10
12	REFRIGERANT CONNECTIONS	10
13	EXPANSION VALVE + PISTON	11
14	CONDENSATE DRAIN TUBING	12
15	AIR FILTER (not factory-installed)	13
16	FILTER INSTALLATION DIMENSIONS	14
17	WIRING DIAGRAM	15
18	ELECTRIC WIRING GAUGE	18
19	ELECTRIC HEAT KIT INSTALLATION (Optional)	19
20	TROUBLESHOOTING	20

This document is customer property and needs to remain with this unit. These instructions do not cover all of the different variations between systems, nor does it provide for every possible contingency that can arise during installation. All phases of this installation must comply with **NATIONAL, STATE, AND LOCAL CODES**. This manual could change without expressed written notice. Visit mrcool.com/documentation for the latest versions.

1 SAFETY



This is a safety alert symbol. When you see this symbol on labels or in manuals, be alert to the potential for personal injury.



This is an attention alert symbol. When you see this symbol on labels or in manuals, be alert to the potential for personal injury.



WARNING

Disconnect all power to unit before installing or servicing. More than one disconnect switch may be required to de-energize the equipment. Hazardous voltage can cause severe personal injury or death.



WARNING

If removal of the blower assembly is required, all disconnect switches supplying power to the equipment must be de-energized and locked (if not in sight of unit), so the field power wires can be safely removed from the blower assembly. Failure to do so can cause electrical shock, resulting in personal injury or death.



WARNING

Because of possible damage to equipment or personal injury, installation, service, and maintenance should only be performed by trained, qualified service personnel. Consumer service is recommended only for filter cleaning/replacement. Never operate the unit with the access panels removed.



WARNING

These instructions are intended as an aid to qualified, licensed service personnel for proper installation, adjustment, and operation of this unit. Read these instructions thoroughly before attempting installation or operation. Failure to follow these instructions may result in improper installation, adjustment, service or maintenance possibly resulting in fire, electrical shock, property damage, personal injury or death.



WARNING

The unit must be properly and permanently grounded. Failure to do so could result in electrical shock causing personal injury or death.



WARNING

PROPOSITION 65: This appliance contains fiberglass insulation.

All manufacturer products meet current federal OSHA Guidelines for safety. California Proposition 65 warnings are required for certain products, which are not covered by the OSHA standards.

California's Proposition 65 requires warnings for products sold in California that contain or produce any of the over 900 listed chemicals known to the State of California to cause cancer or birth defects. These include, fiberglass insulation, lead contained in brass, and combustion products from natural gas.

All "new equipment" shipped for sale in California will have labels stating that the product contains and/or produces Proposition 65 chemicals. Although we have not changed our processes, having the same label on all our product facilitates manufacturing and shipping. We cannot always know "when, or if" products will be sold in the California market.

You may receive inquiries from customers about chemicals found in, or produced by, some of our heating and air-conditioning equipment, or found in natural gas used with some of our products. Listed below are those chemicals and substances commonly associated with similar equipment in our industry and other manufacturers.

- Glass Wool (Fiberglass) Insulation
- Carbon Monoxide (CO)
- Formaldehyde
- Benzene

More details are available at the websites for OSHA (Occupational Safety and Health Administration), at www.osha.gov and the State of California's OEHHA (Office of Environmental Health Hazard Assessment), at www.oehha.org. Consumer education is important since the chemicals and substances on the list are found in our daily lives. Most consumers are aware that products present safety and health risks, when improperly used, handled and maintained.



WARNING

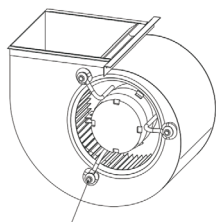

BLOWER MOTOR SHIPPING BOLT

Make sure the blower motor support is tight, which is secured by 3-motor mount bolts. Then check to see if the wheel is secured to motor shaft before operating unit.



WARNING

The first 3 feet (36 inches) of the supply air plenum and ductwork must be constructed of sheet metal as required by NFPA 90B. The supply air plenum or duct must also have a solid sheet metal bottom directly under the unit with no openings, registers or flexible air ducts located in it.

If flexible supply air ducts are used, they can only be located in the vertical walls of the rectangular plenum and must be a minimum of 6 inches from the solid bottom. The metal plenum of the duct may be connected to the combustible floor base, if not, it must be connected to the unit supply duct that is exposed to the supply air opening from the downflow unit. Exposing combustible (non-metal) material to the supply opening of a downflow unit can cause a fire, resulting in property damage, personal injury, or death.

Exception warning to downflow:

Installations on a concrete floor slab, with supply air plenum and ductwork completely encased, must use at least 2 inches of concrete (See NFPA 90A).

2 GENERAL

The unit can be positioned for bottom return air in the upflow position, left and right return in the horizontal position, or top return in downflow position.

This Air Handler provides the flexibility for installation in any upflow, downflow, or horizontal application. The direct drive motors provide a selection of air volumes to match any application. The 3-Speed motors can be adjusted to provide air flow to meet desired applications.

Top and side power control wiring, and accessible screw terminals for control wiring, all combine to make the installation easy, and minimize installation cost. Please contact your local distributor (Refer to Fig.1).

The appliance is only intended to supply conditioned air to one room.

3 UNIT DIMENSIONS

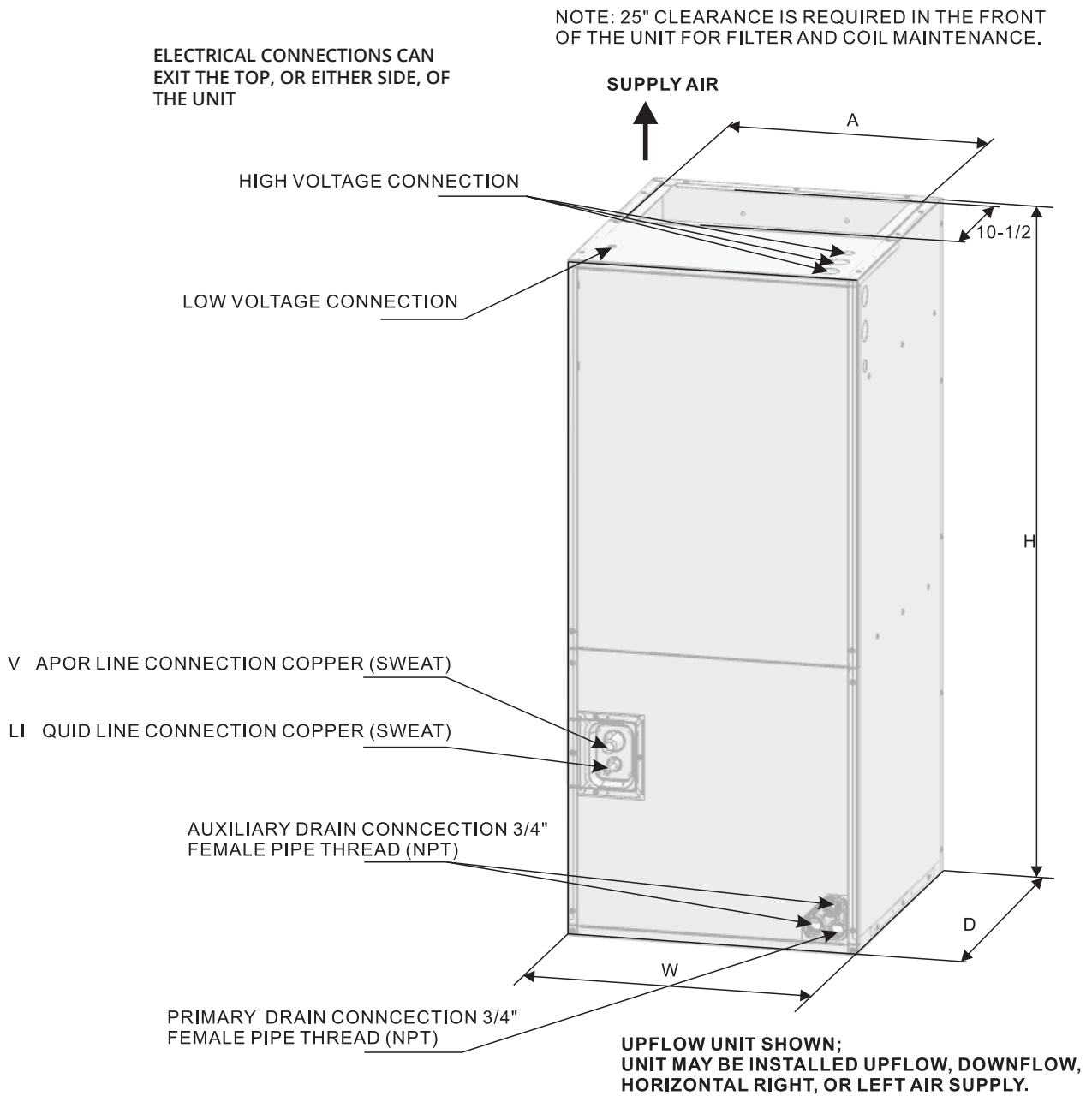

Fig.1 DIMENSIONS

DIMENSIONAL DATA

MODEL SIZE	Dimensions inch[mm]				
	UNIT HEIGHT "H" IN. [mm]	UNIT WIDTH "W" IN. [mm]	UNIT LENGTH "D" IN. [mm]	SUPPLYDUCT "A" IN[mm]	LIQUID LINE/ VAPOR LINE IN
18K	45-3/4"[1162]	19-5/8"[500]	22"[560]	17-7/8"[454]	3/8" / 3/4"
24K	45-3/4"[1162]	19-5/8"[500]	22"[560]	17-7/8"[454]	3/8" / 3/4"
30K	45-3/4"[1162]	19-5/8"[500]	22"[560]	17-7/8"[454]	3/8" / 3/4"
36K	45-3/4"[1162]	19-5/8"[500]	22"[560]	17-7/8"[454]	3/8" / 3/4"
42K	45-3/4"[1162]	19-5/8"[500]	22"[560]	17-7/8"[454]	3/8" / 3/4"
48K	53-1/8"[1350]	22"[560]	24-1/2"[623]	19-1/2"[496]	3/8" / 7/8"
60K	53-1/8"[1350]	22"[560]	24-1/2"[623]	19-1/2"[496]	3/8" / 7/8"

Table 1

4 VERTICAL UPFLOW

- 1) Vertical Upflow configuration is the factory set on all models (**see Fig 1**)
- 2) If a side return air opening is required, field fabricate a return air plenum with an opening large enough to supply unit and strong enough to support unit weight.
- 3) If return air is to be ducted, install duct flush with floor. Use fireproof resilient gasket 1/8 in. to 1/4 in. thick between the ducts, unit, and floor. Set unit on the floor over the opening.

IMPORTANT NOTE

Torque applied to drain connections should not exceed 15 ft. lbs. (**Refer to Fig.1 & 2**).

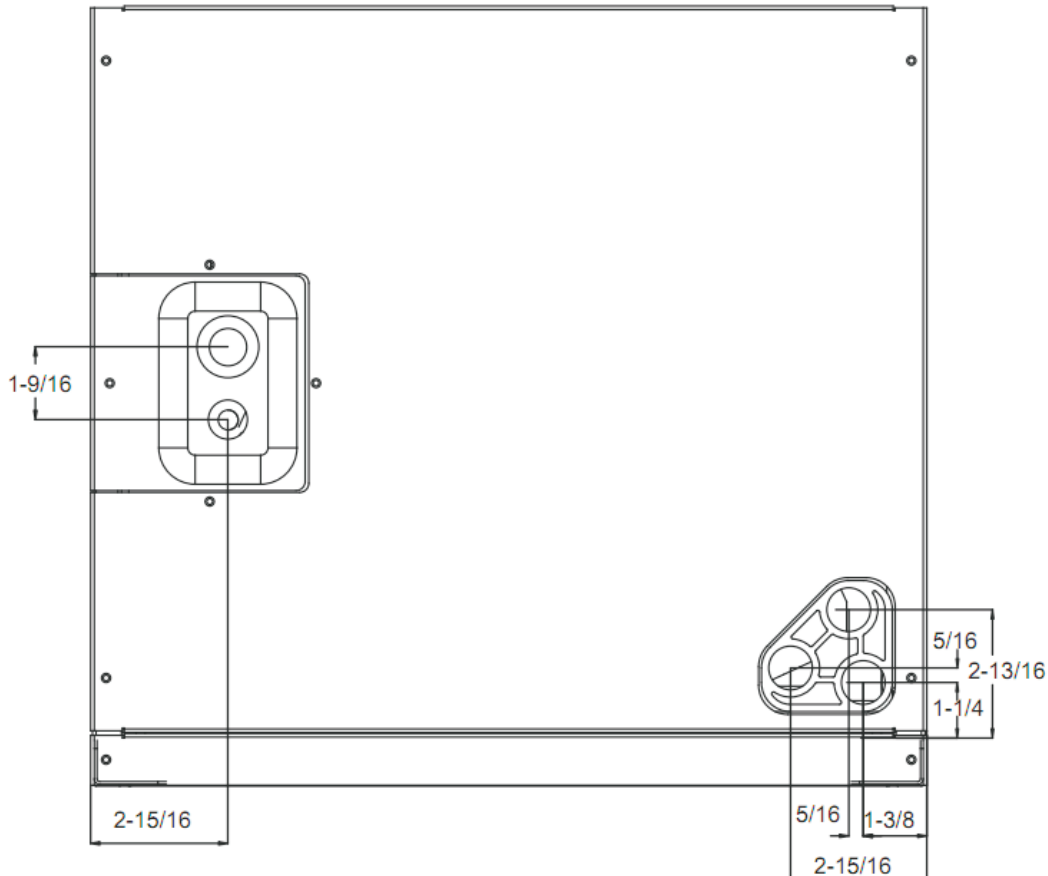

Fig.2 DIMENSIONS FOR FRONT CONNECT COIL

5 VERTICAL DOWNFLOW

Conversion to Vertical Downflow: A vertical upflow unit may be converted to vertical downflow. Remove the door and indoor coil and reinstall 180 degrees from its original position (**Refer to Fig. 3**).

IMPORTANT: To comply with certification agencies and the National Electric Code for horizontal right application, the circuit breaker(s) on field-installed electric heater kits must be re-installed, per the procedure below, so that the breaker switch "on" position and marking is up and, "off" position and marking is down.

To rotate breaker(s): Rotate one breaker set (circuit) at a time, starting with the one on the right. Loosen both lugs on the load side of the breaker (make sure that wires are identified and are reinstalled into proper breaker). Wires are bundled with wire ties, one bundle going to the right lug and one bundle going to the left lug.

- Using a screwdriver, lift the blue plastic tab with hole away from breaker until breaker releases from mounting opening.
- With breaker held in hand, rotate breaker so that the "on" position is up, and "off" position is down (with unit in planned vertical mounting position). Insert right wire bundle into top right breaker lug, ensuring all strands of all the wires are inserted fully into lug, and no wire insulation is in the lug.
- Tighten lug as tight as possible while holding circuit breaker. Check wires and make sure each wire is secure and none are loose. Repeat for left wire bundle in left top circuit breaker lug.
- Replace breaker by inserting the breaker mounting tab, opposite of the white pull tab in opening, hook mounting tab over edge in opening.
- Using a screwdriver, pull the blue tab with hole away from breaker while setting that side of breaker into the the opening. When breaker is in place, release tab, which will lock circuit breaker into location in opening.
- Repeat above operation for remaining breaker(s) (if more than one is provided).
- Replace single point wiring jumper bar, if it is used, on line side of breaker and tighten securely.
- Double check wires and lugs to make sure all are secure and tight. Check to make sure unit wiring to circuit breaker load lugs match that shown on the unit wiring diagram.

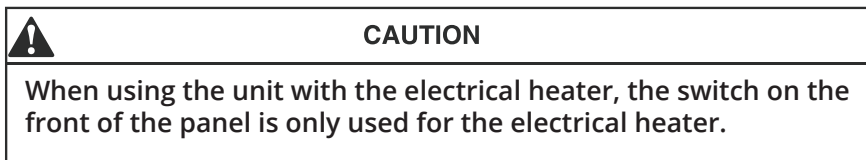

6 HORIZONTAL

Horizontal right is the default factory configuration for the units.

Conversion to Horizontal: A vertical upflow unit may be converted to horizontal left by removing indoor coil assembly and reinstalling coil as shown for left hand air supply. And reinstall coil in unit as shown for left hand air supply.

- Rotate unit into the downflow position, with the coil compartment on top and the blower compartment on bottom (**Refer to Fig. 3**).
- Reinstall the indoor coil 180° from the original position. Ensure the retaining channel is fully engaged with the coil rail (**Refer to Fig. 3**).
- Secondary drain pan kits are recommended when the unit is configured for the horizontal position over a finished ceiling and/or living space.

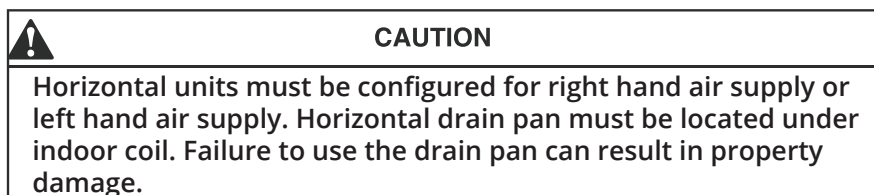

Conversion in Horizontal Direction: Horizontal right-hand supply can be changed to horizontal left-hand supply by removing the indoor coil and reinstalling 180 ° from the original position.

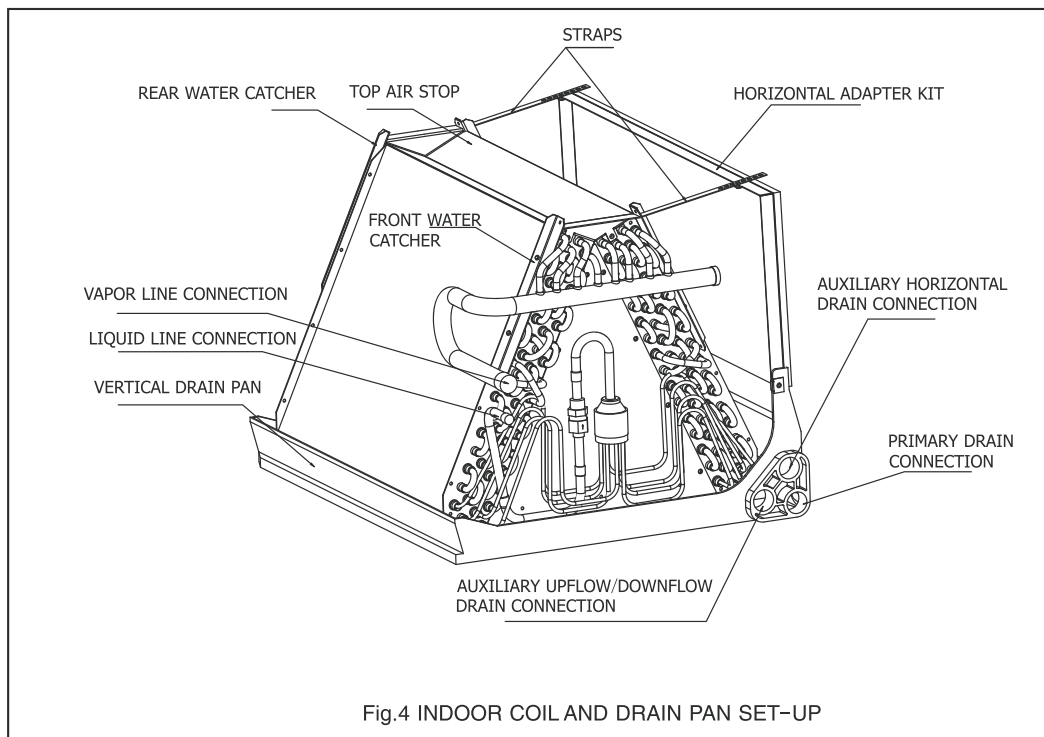
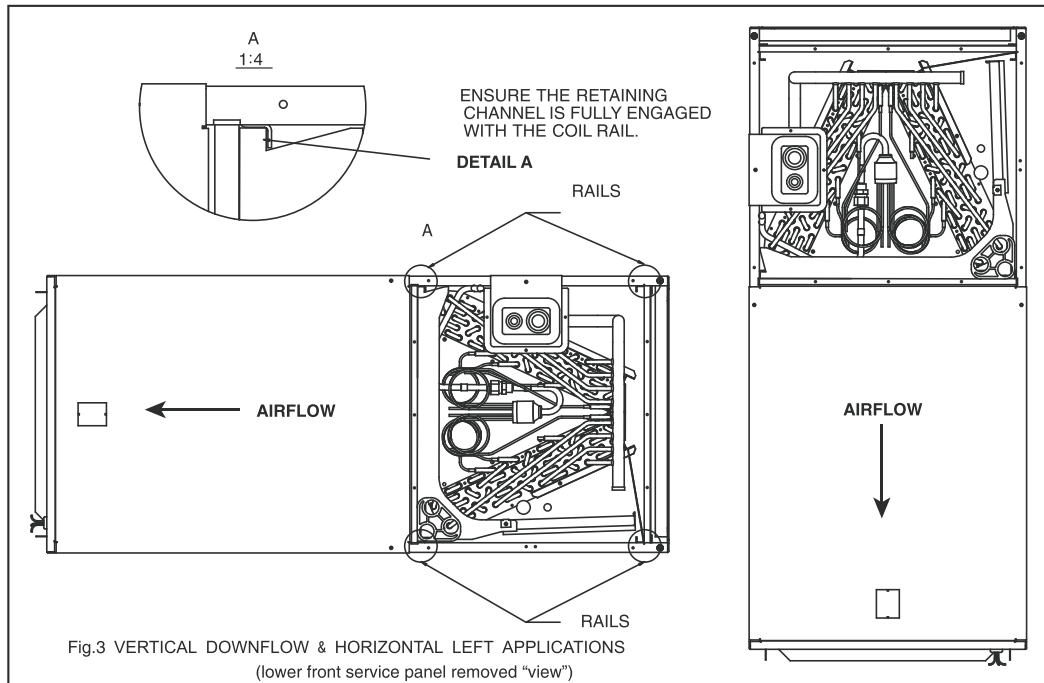

Market Model		14SEER AHU						
		HAH14018	HAH14024	HAH14030	HAH14036	HAH14042	HAH14048	HAH14060
Indoor external static pressure	InWC	0.10	0.10	0.15	0.15	0.15	0.20	0.20
Indoor air flow	CFM(hi/mi/lo)	723/610/500	938/804/738	1204/1060/919	1376/1235/1161	1562/1385/1208	1695/1574/1434	1695/1574/1434
Indoor external static pressure	InWC	0.18	0.18	0.23	0.23	0.23	0.28	0.28
Indoor air flow	CFM(hi/mi/lo)	1364/1229/849	1595/1366/1256	2046/1955/1562	2340/2100/1974	2480/2430/2074	2882/2676/2437	2882/2676/2437

Table 2

7 ELECTRICAL WIRING

Field wiring must comply with the National Electric Code and any applicable local ordinance.



WARNING

Disconnect all power to unit before installing or servicing. More than one disconnect switch may be required to de-energize the equipment. Hazardous voltage can cause severe personal injury or death.

8 POWER WIRING

It is important that proper electrical power is available for connection to the unit model being installed. Please refer to the unit nameplate, wiring diagram, and electrical data in the installation instructions.

- If required, install a branch circuit disconnect of adequate size, located within sight of, and readily accessible to the unit.
- **IMPORTANT:** After the Electric Heater is installed, units may be equipped with one, two, or three 30/60 amp. circuit breakers. These breaker(s) protect the internal wiring in the event of a short circuit and also serve as a disconnect. Circuit breakers installed within the unit do not provide overcurrent protection of the supply wiring and therefore may be sized larger than the branch circuit protection.
- Supply circuit power wiring must be 167°F (75°C) minimum copper conductors only. Refer to the Electrical Data In this section for ampacity, wire size, and circuit protector requirement. Supply circuit protective devices may be either fuses or "HACR" type circuit breakers.
- Power wiring may be connected to either the right side, left side, or top. Concentric knockouts are provided for connection of power wiring to unit.
- Power wiring is connected to the power terminal block in unit electric cabinet.

9 CONTROL WIRING

IMPORTANT: Class 2 low voltage control wiring should not be run in conduit with main power wiring and must be separated from power wiring, unless class 1 wire of proper voltage rating is used.

- Low voltage control wiring should be 18 Awg. color-coded. For lengths longer than 100 ft., 16 Awg. wire should be used.
- See wiring diagrams attached to indoor and outdoor sections to be connected.
- Make sure, after installation, separation of control wiring and power wiring has been maintained.

10 GROUNDING



WARNING

The unit must be properly and permanently grounded. Failure to do so can result in electrical shock causing personal injury or death.

- Grounding may be accomplished by grounding metal conduit when installed in accordance with electrical codes to the unit cabinet.
- Grounding may also be accomplished by attaching ground wire(s) to ground lug(s) provided in the unit wiring compartment.
- Ground lug(s) are located close to wire entrance on left side of the unit (upflow). Lug(s) may be moved to marked locations near wire entrance on right side of the unit (upflow). If alternate location is more convenient.
- Use of multiple supply circuits require grounding of each circuit to lug(s) provided in unit.

11 ELECTRICAL DATA

MODEL	VOLTAGE	HERTZS	HP	RPM	SPEEDS	CIRCUIT AMPS.	MAXIMUM CIRCUIT PROTECTOR
18K	208/230	60	1/7	470	3	0.73	5(A)
24K	208/230	60	1/6	530	3	0.8	5(A)
30K	208/230	60	1/4	640	3	1.21	5(A)
36K	208/230	60	2/7	730	3	1.53	5(A)
42K	208/230	60	3/8	840	3	1.95	5(A)
48K	208/230	60	2/5	820	3	1.92	5(A)
60K	208/230	60	2/5	920	3	2.55	15(A)

Table 3

Applicable to 13-14SEER

The air distribution system has the greatest effect on airflow. The duct system is totally controlled by the contractor. For this reason, the contractor should use only industry-recognized procedures.

Heat pump systems require a specified airflow. Each ton of cooling requires between 350 and 450 cubic feet of air per minute (CFM), or 400 CFM nominally. Duct design and construction should be carefully done. System performance can be lowered dramatically through bad planning or workmanship.

Air supply diffusers must be selected and located carefully. They must be sized and positioned to deliver treated air along the perimeter of the space. If they are too small for their intended airflow, they become noisy. If they are not located properly, they can create drafts. Return air grilles must be properly sized to carry air back to the blower. If they are too small, they also cause noise.

The installers should balance the air distribution system to ensure proper, quiet airflow to all rooms in the home. This ensures a comfortable living space. An air velocity meter or airflow hood can give a reading of system CFM.

12 REFRIGERANT CONNECTIONS

Keep the coil connections sealed until refrigerant connections are made. See the Installation Instructions for the outdoor unit for details on line sizing, tubing installation, and charging information.

Coil is shipped with "No charge". Evacuate the system before charging with refrigerant.

Install refrigerant tubing so that it does not block service access to the front of the unit.

Nitrogen should flow through the refrigerant lines while brazing.

Use a brazing shield to protect the cabinet's paint, and a wet rag to protect the rubber grommet from being damaged by torch flames. After the refrigerant connections are made, seal the gap around the connections with a pressure sensitive gasket.

13 EXPANSION VALVE + PISTON INFORMATION

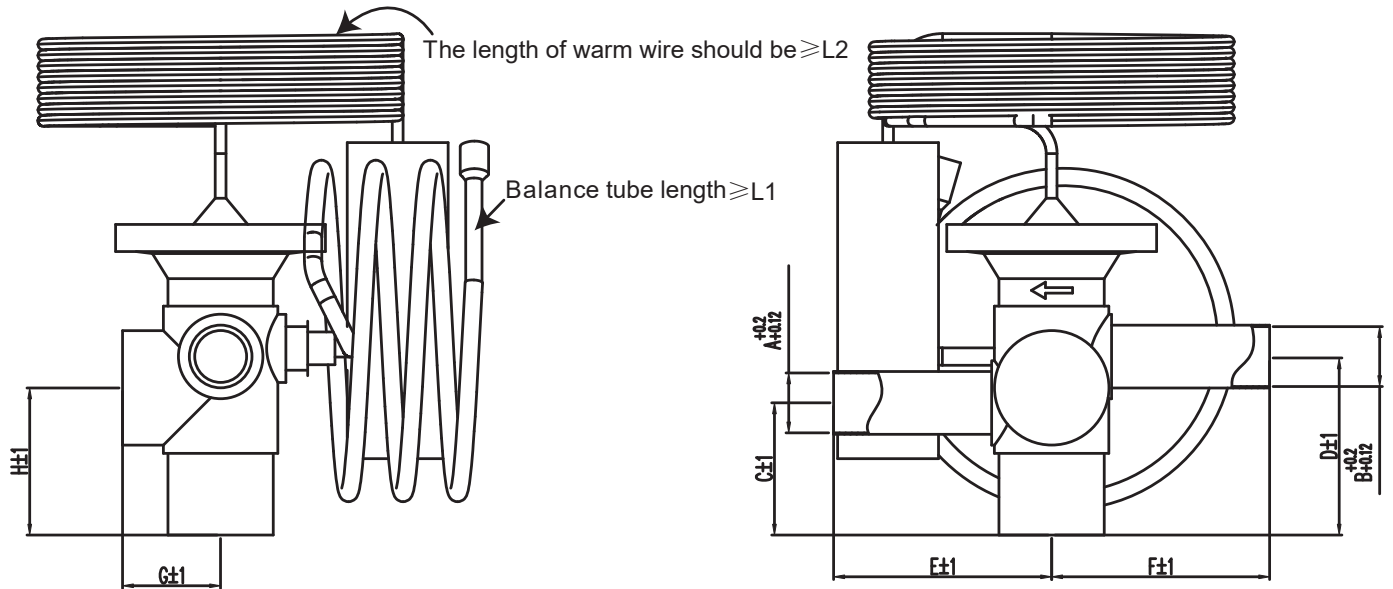

Thermal Expansion Valve (14 SEER Heat Pump)

Unit: mm

NO.	BOM	Model	A	B	C	D	E	F	G	H	L1	L2	Remark
1	801600400099	18/24/30/36/42K	12.7	9.52	24	32.5	42	42	18	27	800	800	Emerson NCE3ZAA ODF
2	801600400101	48/60K	12.7	9.52	24	32.5	42	42	18	27	800	800	Emerson NCE5ZAA ODF

- A: Outlet inner diameter
- B: Inlet diameter
- C: Length from outlet center to bottom of valve body
- D: Length from inlet center to bottom of valve body
- E: Length from outlet center to valve body center
- F: Length from inlet center to valve body center
- G: Length between the center of the adjustable screw and the back of the valve body
- H: Length between the center of valve body and bottom of valve body
- L1: Balance tube length
- L2: Warm wire length

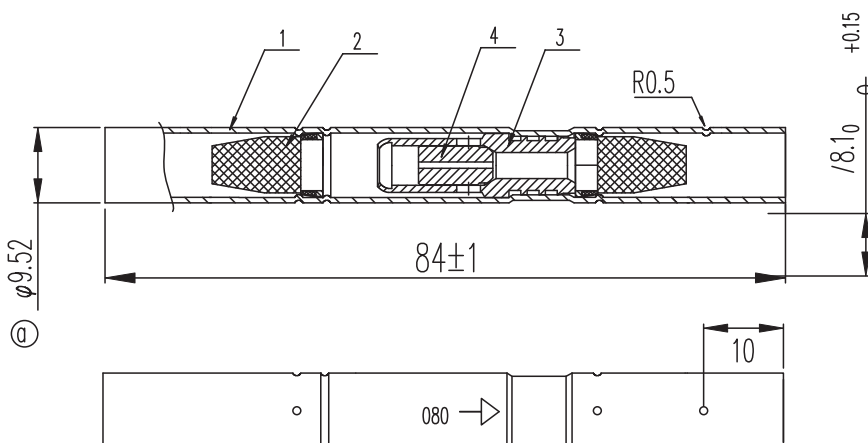

Piston (14 SEER Heat Pump)

Model	Piston	BOM	
18K	036	801600300100	One Way Valve
24K	045	801600300085	One Way Valve
30K	055	801600300102	One Way Valve
36K	045	801600300085	One Way Valve
42K	055	801600300102	One Way Valve
48K	065	801600300088	One Way Valve
60K	075	801600300089	One Way Valve

14 CONDENSATE DRAIN TUBING

Consult local codes for specific requirements.

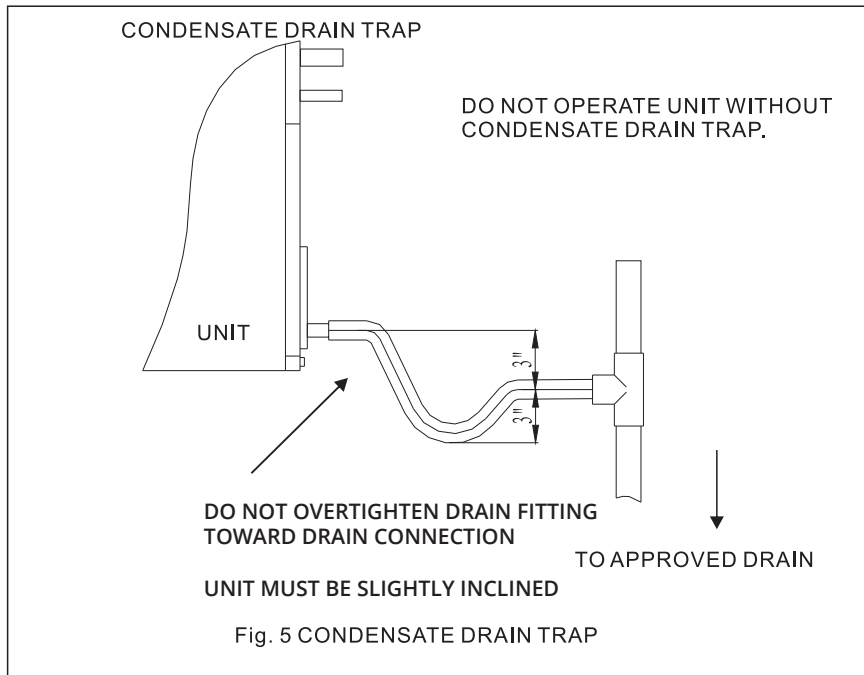

IMPORTANT

1. When making drain fitting connections to the drain pan, use a thin layer of Teflon paste, silicone, or Teflon tape and install. Hand-tighten the fittings.
2. When making drain fitting connections to drain pan, do not overtighten. Over tightening fittings can split pipe connections on the drain pan.

(Continued on next page)

- Install drain lines so they do not block service access to front of the unit. A minimum clearance of 2 feet (24 inches) is required for filter, coil or blower removal, and service access.
- Make sure unit is level or pitched slightly toward primary drain connection so that water will drain completely from the pan (Refer to **Fig. 5**)
- Use a drain line sized properly to match size of condensate drain pan.
- All drain lines must be pitched downward and away from the unit with a minimum of 1/8 in. per foot of line to ensure proper drainage.
- Do not connect condensate drain line to a closed or open sewer pipe. Run condensate to an open drain or run line to a safe outdoor area.
- The drain line should be insulated where necessary to prevent sweating and damage from condensate forming on the outside surface of the line.
- Make provisions for disconnecting and cleaning of the primary drain line should it become necessary. Install a 3 inch trap in the primary drain line as close to the unit as possible. Make sure that the top of the trap is below the connection to the drain pan to allow complete drainage of pan (Refer to **Fig. 5**).
- Auxiliary drain line should be run to a place where it will be noticeable if it begins to drain. Homeowner should be warned that a problem exists if water should begin running from the auxiliary drain line.
- Plug the unused drain connection with the plugs provided in the parts bag, using a thin layer of teflon paste, silicone, or teflon tape to form a water tight seal.
- Test condensate drain pan and drain line after installation is complete. Pour water into drain pan, enough to fill drain trap and line. Check to make sure drain pan is draining completely, no leaks are found in drain line fittings, and water is draining from the termination of the primary drain line.

15 AIR FILTER (NOT FACTORY-INSTALLED)

- An external filter, or other means of filtration, is required. Units should be sized for a maximum of 300 feet/min. air velocity, or what is recommended for the filter type installed.

Filter application and placement are critical to airflow, which may affect the heating and cooling system performance. Reduced airflow can shorten the life of the system's major components, such as motor, limits, elements, heat relays, evaporator coil, or compressor. Consequently, we recommend that the return air duct system have only one filter location. For systems with a return air filter grill or multiple filter grills, they can have a filter installed at each of the return air openings.

If adding high efficiency filters or electronic air filtration systems, it is very important that the air flow is not reduced. If air flow is reduced, the overall performance and efficiency of the unit will be reduced. It is strongly recommended that a professional installation technician is contacted to ensure these filtration systems are installed correctly.

IMPORTANT: DO NOT DOUBLE FILTER THE RETURN AIR DUCT SYSTEM. DO NOT FILTER THE SUPPLY AIR DUCT SYSTEM. THIS WILL CHANGE THE PERFORMANCE OF THE UNIT AND REDUCE AIRFLOW.



WARNING

Do not operate the system without filters. A portion of the dust entrained in the air may temporarily lodge in the duct runs and at the supply registers. Any circulated dust particles could be heated and charred by contact with the air handler elements. This residue could soil ceilings, walls, drapes, carpets, and other articles in the house. Soot damage may occur with filters in place, when certain types of candles, oil lamps, or standing pilots are burned.

16 FILTER INSTALLATION DIMENSIONS

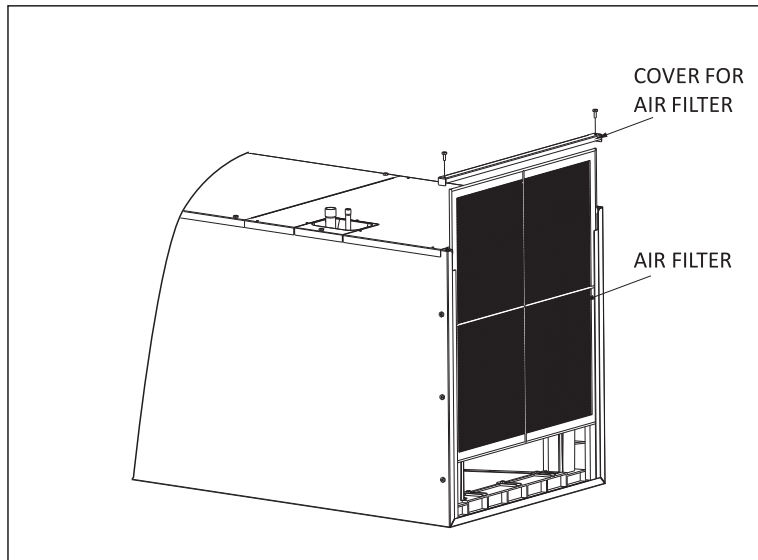

Fig. 6 EXTERNAL FILTER BASE

DIMENSIONAL DATA

MODEL	FILTER SIZE IN[mm]
18/24/30/36/42	18×20[457×508]
48/60	20×22[508×559]

Table 4

AIR FILTER REMOVAL

1. Tear down the two bolts marked A and B, remove the cover for air filter (Refer to **Fig. 6**).
2. Hold the edge of the air filter and extract out .
3. Clean the air filter. A vacuum cleaner or pure water may be used to clean the air filter. If the dust accumulation is too heavy, use soft a brush and mild detergent to clean it and allow it to dry out in cool place.

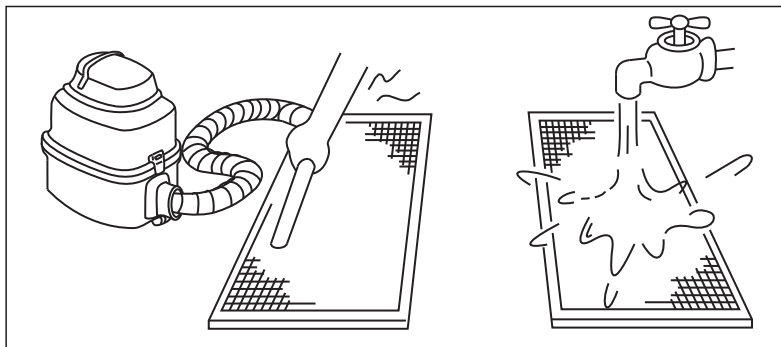

17 WIRING DIAGRAMS

Thermostat Wiring - 6 Conductor | 18 Guage | Low Voltage

Control Wiring for A/C Systems only

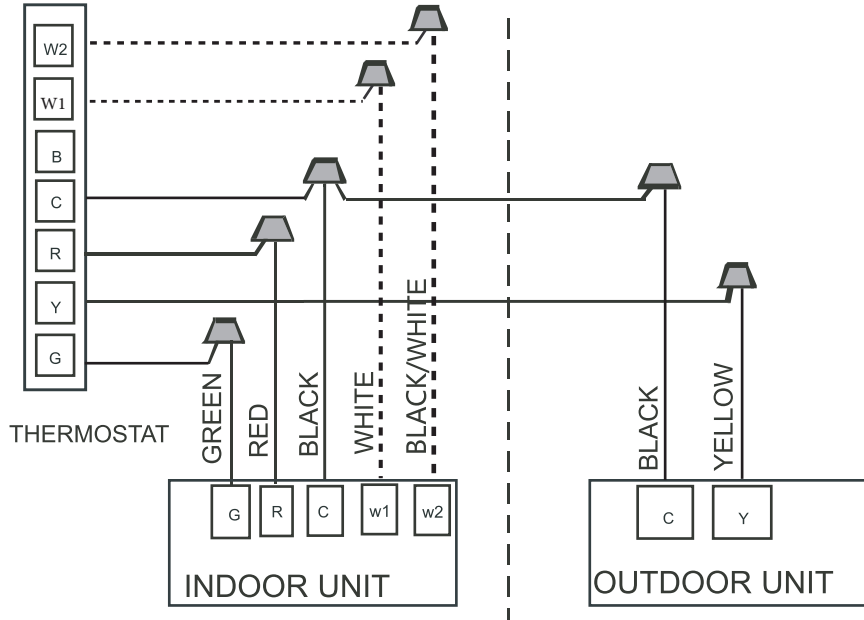

Control Wiring for A/C Systems.

Control Wiring for Heat Pump Systems

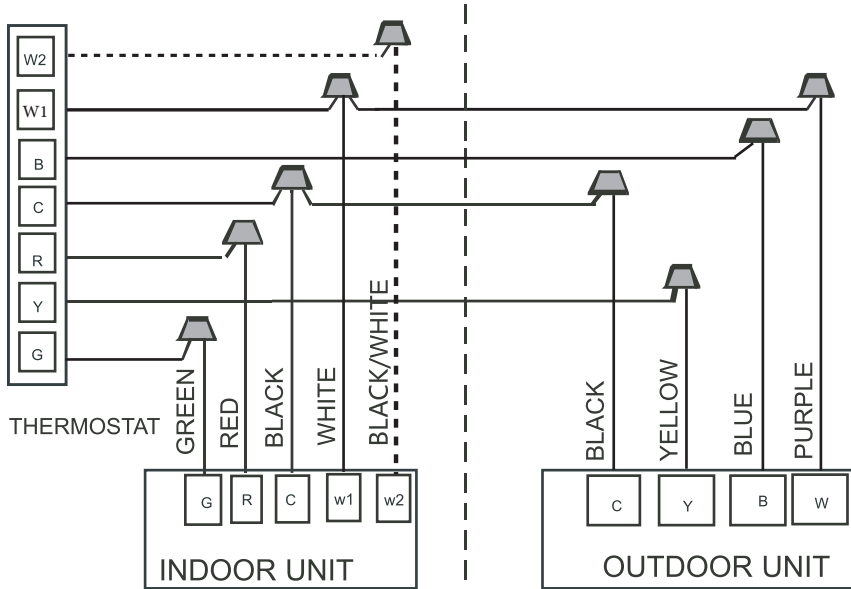

Control Wiring for H/P Systems.

High Voltage Wiring

1. To avoid the electrical shock, please connect the air conditioner with the ground lug. The main power plug in the air conditioner has been joined with the ground wiring, please do not change it freely.
2. Use a dedicated circuit.
3. Do not pull the power wiring hard.
4. When connecting the air conditioner with the ground, observe the local codes.
5. If necessary, use the power fuse, circuit breaker, or the corresponding scale ampere.

Applicable to 18k, 24k, 30k, 36k, 42k of 13-14 SEER

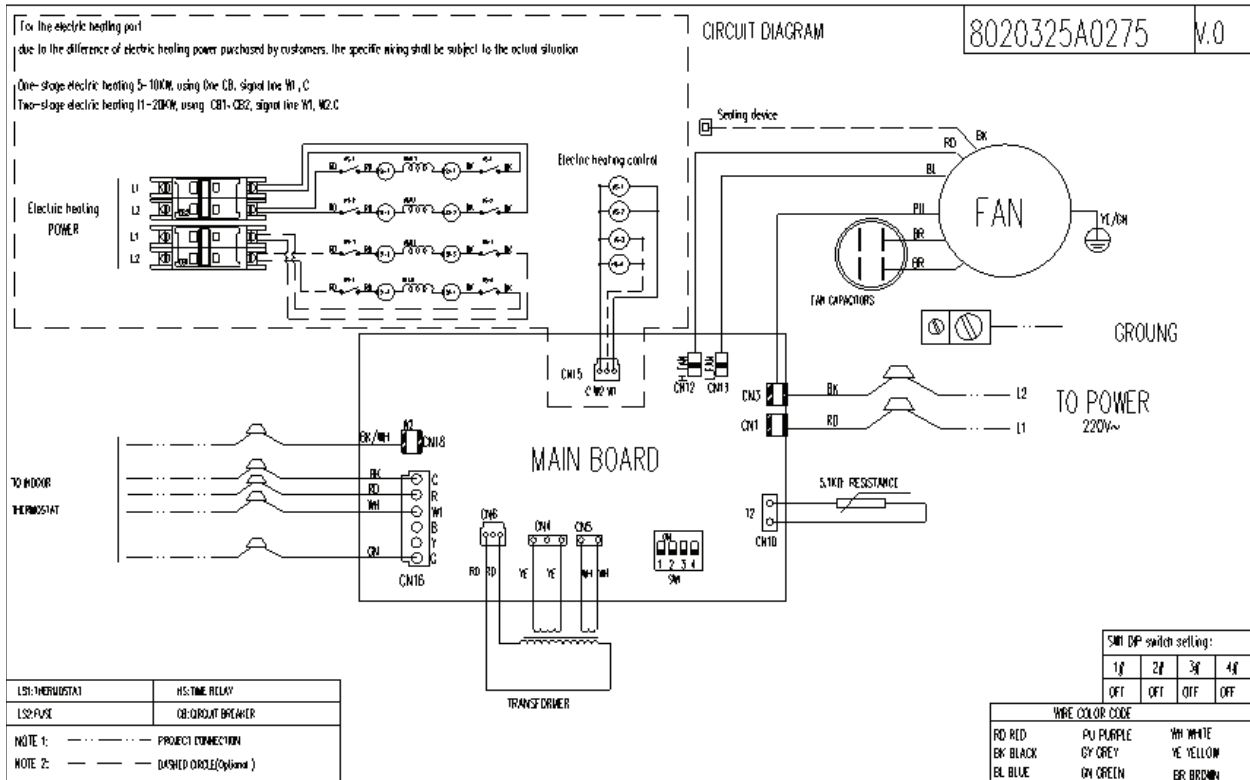

Applicable to 48K of 13-14 SEER

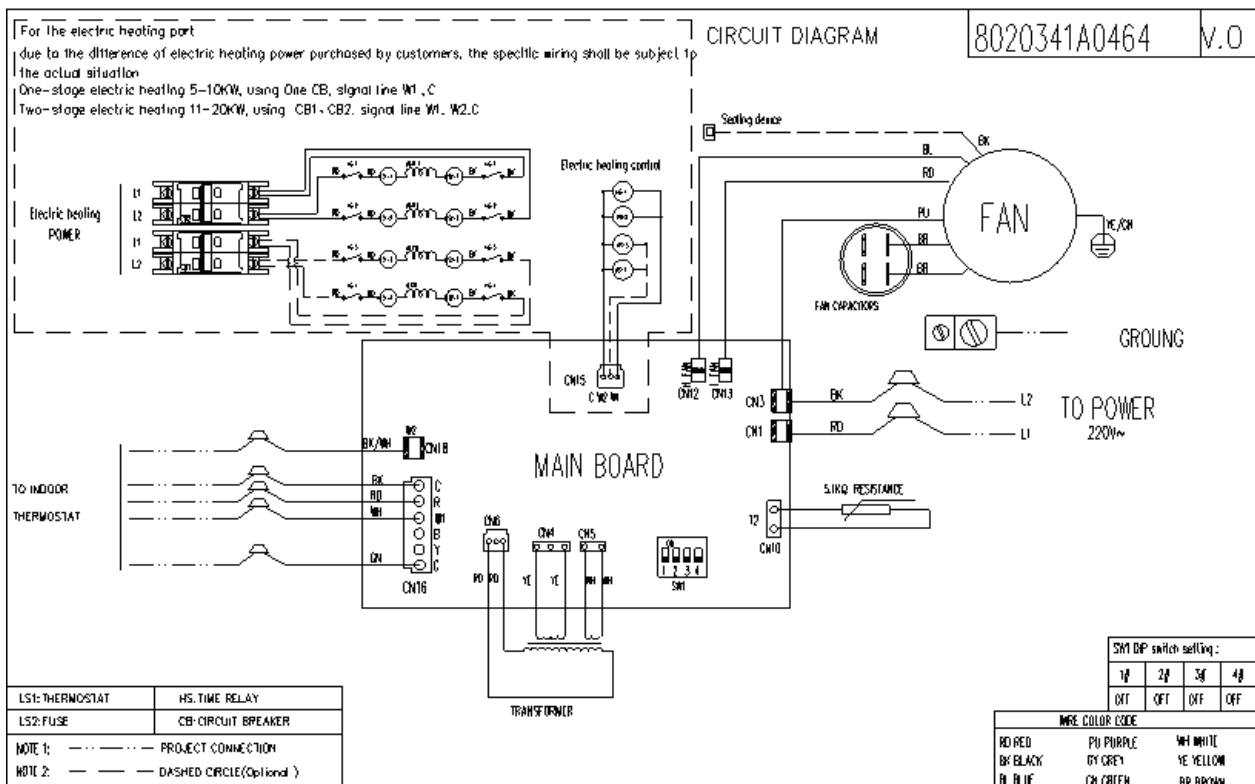

Applicable to 60K of 13-14 SEER

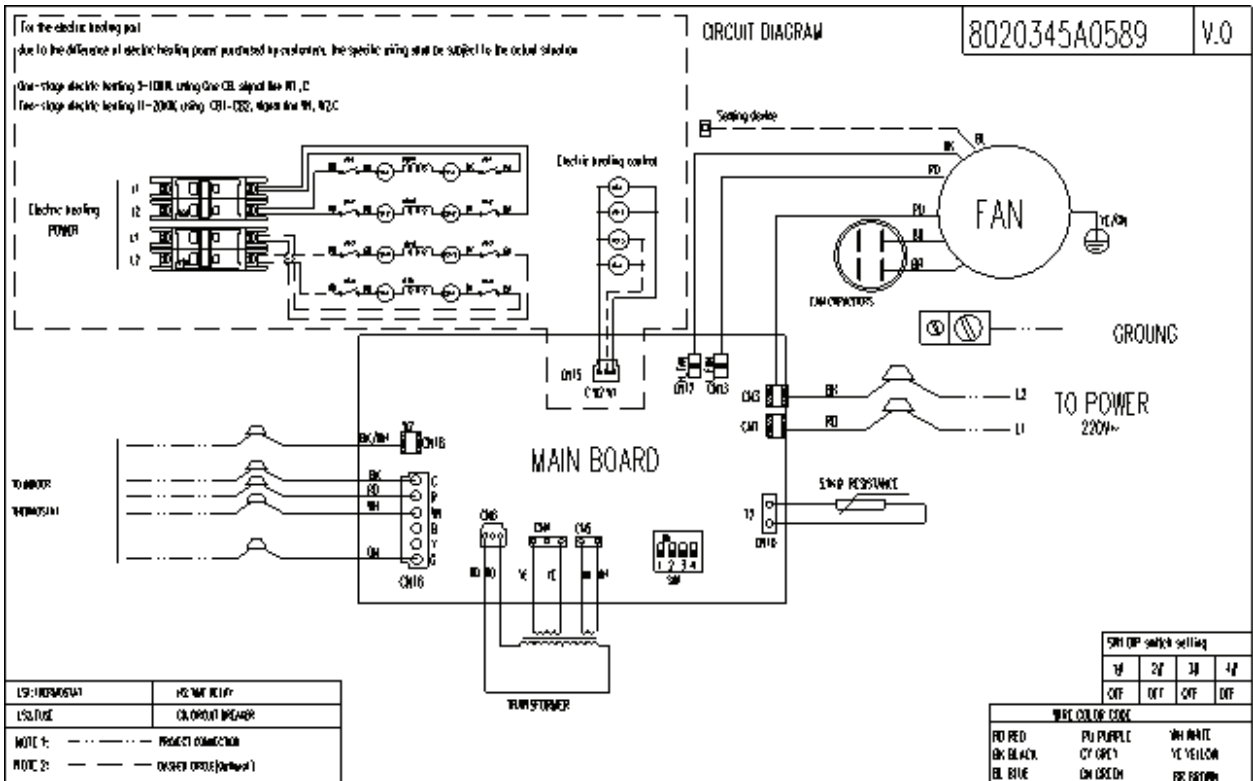

Wiring Diagram to Adjust Blower Volume Speed

To adjust blower speed, use the diagram below to wire according to the desired speed: CN12 is the air volume output port. The air volume is adjusted by connecting the wires with different speeds for the motor to the port CN12. Regardless of the high, medium or low wind speeds, it is only connected to CN12. Do not adjust CN13.

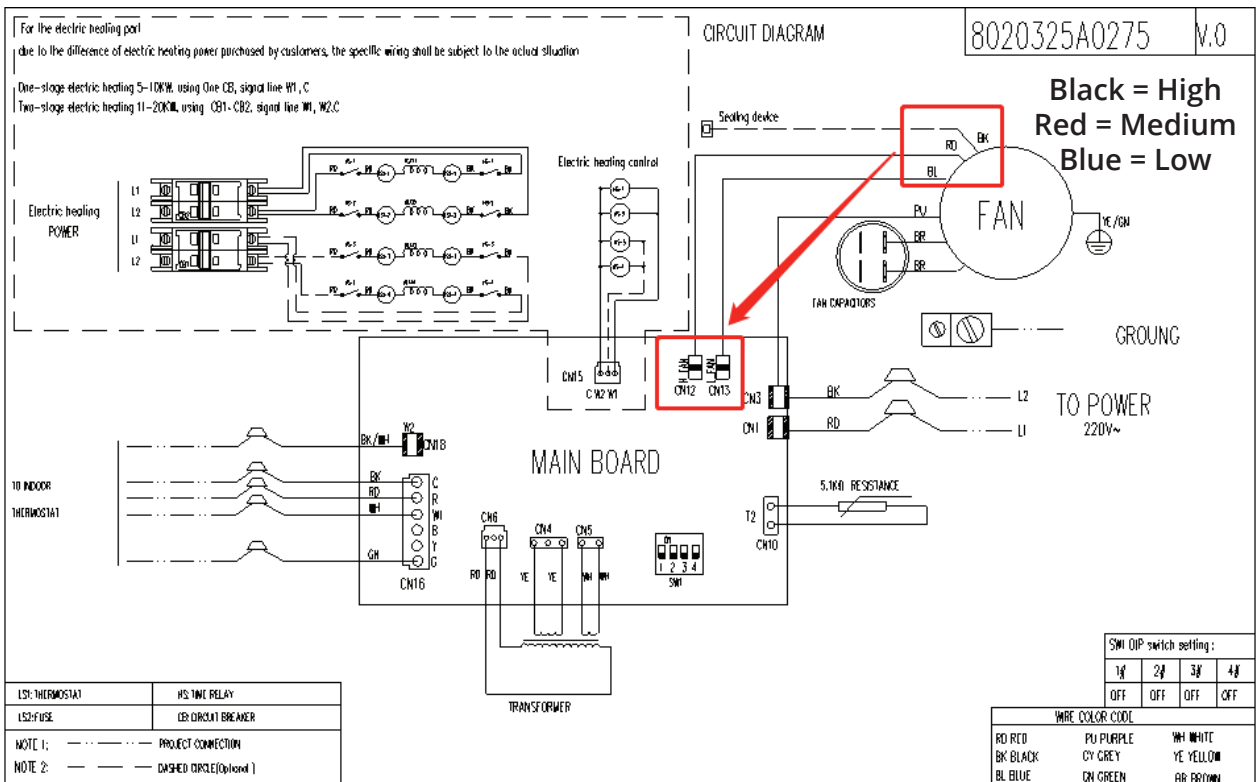

18 ELECTRIC WIRING GAUGE

NOTE: The cross-section areas of wires or lines should not be less than the corresponding line measurements listed in the table below; Besides, if the power wires from the unit are quite long, please choose the windings with larger cross-section area to guarantee the normal power supply.

Table 5

Model (cooling only type)			18K	24K	30K	36K	42K	48K	60K
Line Gauge	Indoor Unit Power Line	Line Quantity	3	3	3	3	3	3	3
		Line Diameter(AWG)	16	16	16	16	16	16	16
	Outdoor Unit Power Line	Line Quantity	3	3	3	3	3	3	3
		Line Diameter(AWG)	14	14	12	12	10	10	10
	Outdoor-Indoor Signal Line	Line Quantity	2	2	2	2	2	2	2
		Line Diameter(AWG)	18	18	18	18	18	18	18
	Thermostat Signal Line	Line Quantity	4	4	4	4	4	4	4
		Line Diameter(AWG)	18	18	18	18	18	18	18

Table 6

Model (cooling & heating type)			18K	24K	30K	36K	42K	48K	60K
Line Gauge	Indoor Unit Power Line	Line Quantity	3	3	3	3	3	3	3
		Line Diameter(AWG)	16	16	16	16	16	16	16
	Outdoor Unit Power Line	Line Quantity	3	3	3	3	3	3	3
		Line Diameter(AWG)	14	14	12	12	10	10	10
	Outdoor-Indoor Signal Line	Line Quantity	2	2	2	2	2	2	2
		Line Diameter(AWG)	18	18	18	18	18	18	18
	Thermostat Signal Line	Line Quantity	6	6	6	6	6	6	6
		Line Diameter(AWG)	18	18	18	18	18	18	18

19 ELECTRIC HEAT KIT INSTALLATION (OPTIONAL)

! CAUTION

1. Ensure that all power supply is disconnected prior to installing the heat kit.
2. A means of strain relief and conductor protection must be provided at the supply wire entrance into cabinet.
3. Only use copper conductors.
4. Installation must follow National Electric Code (NEC) and other applicable codes.
5. If this appliance is installed in an enclosed area such as a garage or utility room with any carbon monoxide producing appliance, ensure the area is properly ventilated to the outside.
6. A filter dryer is recommended for installation based on nominals tonnage. One should be included and zip-tied to the condenser.
7. Use 0.96 as approximate SCFM correction factor for wet coil.

- 1). Refer to the Table below for the appropriate optional heat kit.
- 2). Check for any physical damage; do not install a damaged heat kit.
- 3). Remove the upper side panel from air handler.
- 4). Remove the air duct sealing plate from the air handler.
- 5). Knock out the hole on the front panel.
- 6). Install the heating bracket by sliding it into the air duct hole that you removed the plate from in the previous steps. Align the 4 prongs at the end of the heat kit with the 4 corresponding holes on the opposite side of the air duct hole.
- 7). Install the electrical board bracket and screw it into place. Then, position and install and fasten the electrical board on the bracket which also screws into place.

Air Duct Sealing Plate

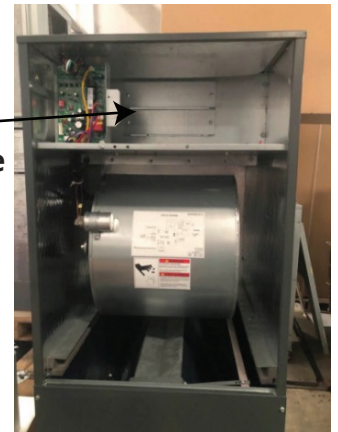

NOTE: When installing the electrical boards, make sure the indoor unit power cable does not snag or come in contact with any of the sharp edges of the sheet metal.

- 8). Insert the signal wire into the electronic control main board on the air handler
- 9). Reinstall the upper side panel to the air handler and check operation.

NOTE: For more detailed information on how to install the electric heat kit, please refer to the instruction manual provided with the kit.



Compatible Heat Kits

Kit #.	Description	Unit Capacity Compatibility
PHK05H	5kW heat strip	18K/24K/30K/36K/42K/48K/60K
PHK07H	7.5kW heat strip	18K/24K/30K/36K/42K/48K/60K
PHK10H	10kW heat strip	24K/30K/36K/42K/48K/60K
PHK15H	15kW heat strip	36K/42K/48K/60K
PHK20H	20kW heat strip	48K/60K



IMPORTANT

You must use a compatible heat kit listed in the above chart. Using an incorrect size, could cause the unit to overheat and/or cause equipment damage.

20 TROUBLESHOOTING INDOOR UNIT

Display mode	Status description
Green light always on	No system alarm and error, normal standby
Red light always on	Evaporator temperature sensor (T2) failure
Green light always on & yellow light flashing	Evaporator high and low temperature protection
Green light flashing	system is in normal operating status

T2 Evaporator temperature sensor failure

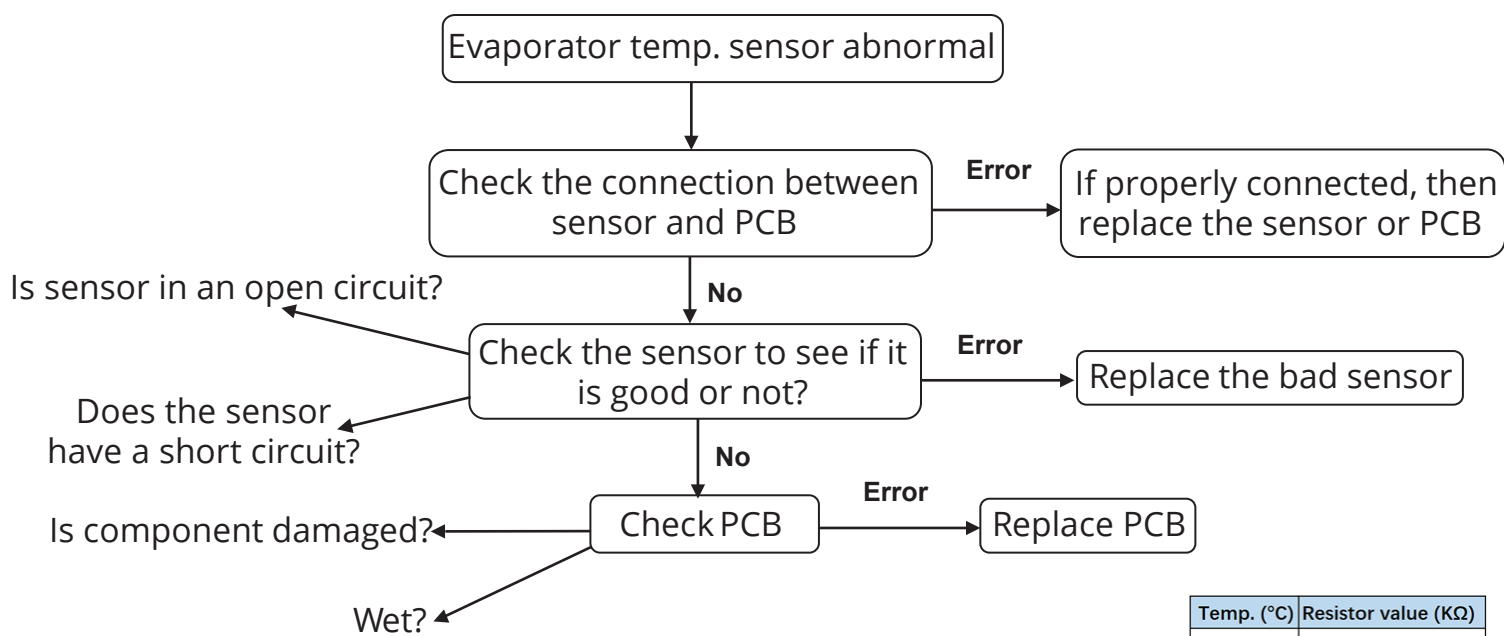

Temp. (°C)	Resistor value (KΩ)
25	5.0
35	3.5

Evaporator high temperature protection (for heating mode)

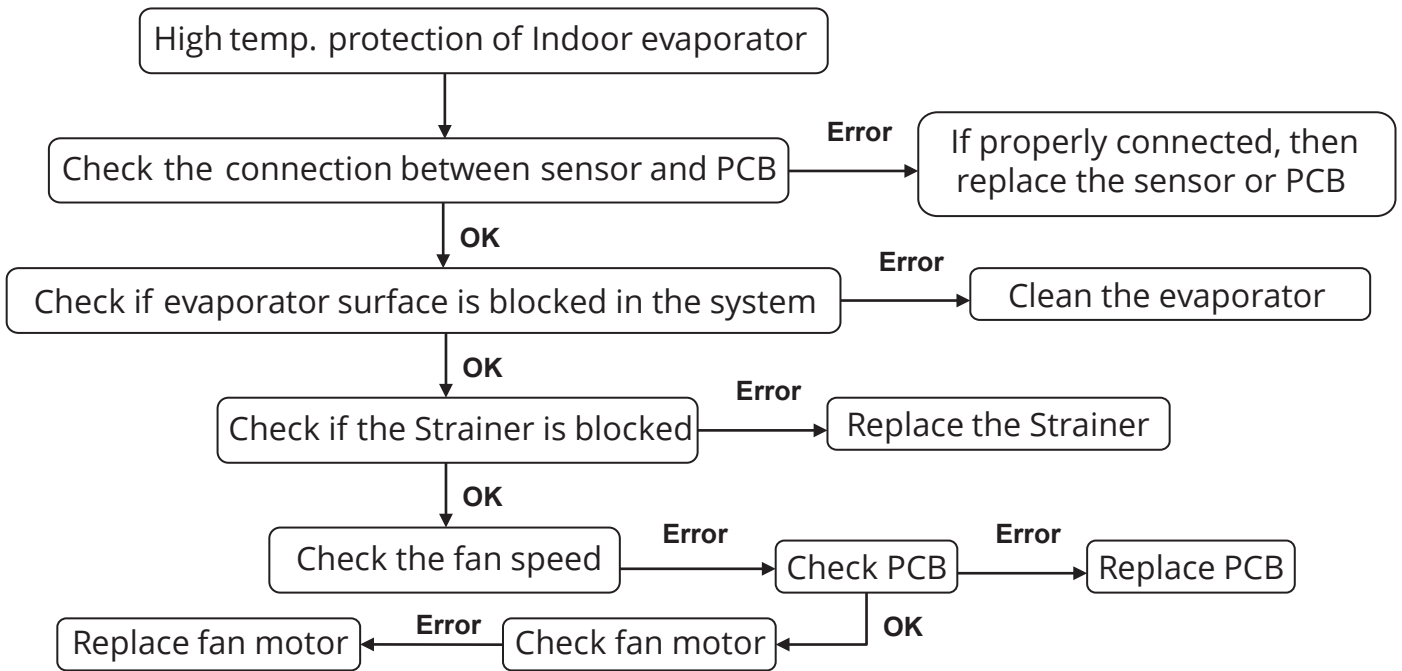

Evaporator low temperature protection (for cooling mode)

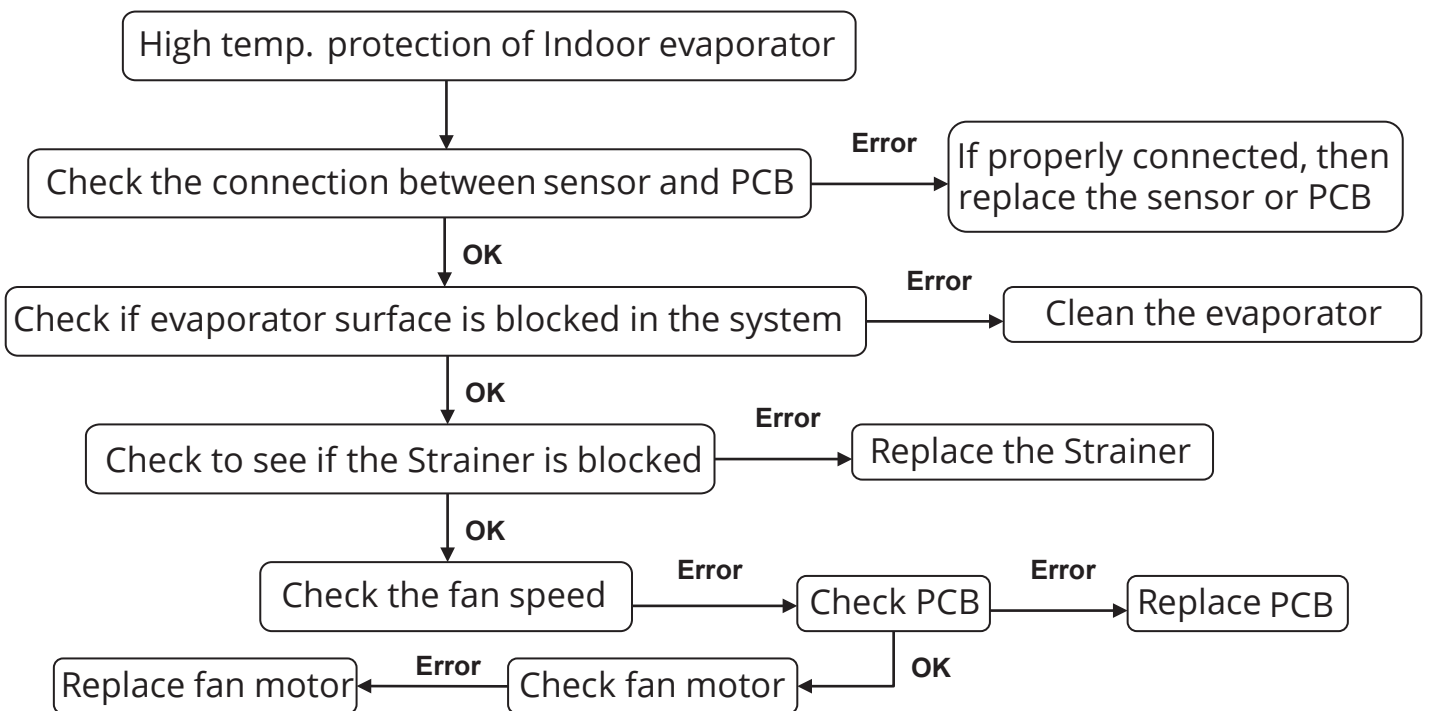

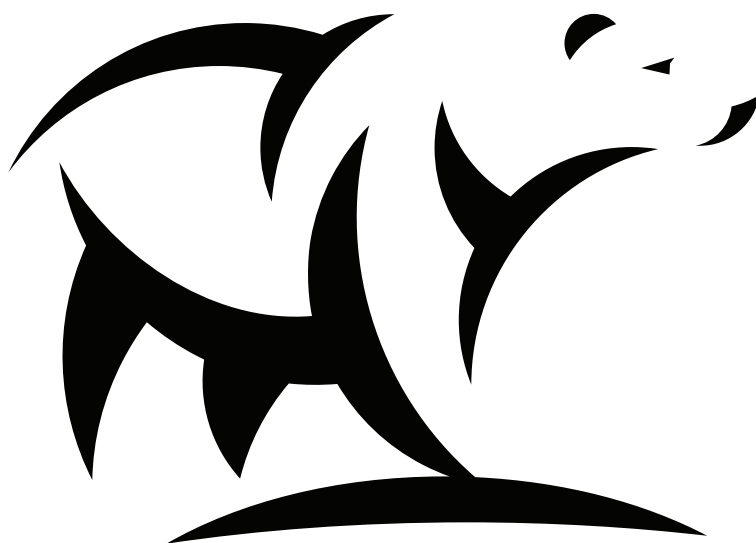

MIRCOOL®

COMFORT MADE SIMPLE

PRODIRECT™ Series



ProDirect™ Series Air Handler

PRODUCT SPECIFICATIONS



Model	HAH14018, HAH14024, HAH14030, HAH14036, HAH14042, HAH14048, HAH14060
Capacity	18K-60K
SEER	14
Speed	3
Throttle Type	TXV



Features

- R410a environmentally friendly refrigerant
- Multi-Position installation (upflow, downflow, horizontal)
- Insulated & painted galvanized steel cabinet
- AHR Certified & ETL Listed
- Automatic Intelligent Defrost Programs
- 24V low voltage control
- Wide operation temperature range
- Detachable filter for cleaning or renewal
- 3-speed, direct-drive blower motor
- Pressure and temperature protection sensors
- “A” Shaped coils (copper tubing & enhanced aluminum fins)

Performance		Units	HAH14018	HAH14024	HAH14030	HAH14036	HAH14042	HAH14048	HAH14060
Capacity	Btu/h		18000	24000	30000	34500	42000	48000	56500
SEER	Btu/h.W		14	14	14	14	14	14	14
Indoor Airflow (Lo/Mi/Hi)	CFM		500/610/723	738/804/938	919/1060/1204	1161/1235/1376	1208/1385/1562	1434/1574/1695	1434/1574/1695
Indoor Noise Level	dB(A)		40	42	48	51	54	55	55
External Static Pressure	Pa		25	25	37	37	37	50	50

Dimensions			HAH14018	HAH14024	HAH14030	HAH14036	HAH14042	HAH14048	HAH14060
Unit (W x H x D)	in		19 ² / ₃ x 45 ³ / ₄ x 22	19 ² / ₃ x 45 ³ / ₄ x 22	19 ² / ₃ x 45 ³ / ₄ x 22	19 ² / ₃ x 45 ³ / ₄ x 22	19 ² / ₃ x 45 ³ / ₄ x 22	22 x 53 ¹ / ₈ x 24	22 x 53 ¹ / ₈ x 24
	mm		500 x 1162 x 560	500 x 1162 x 560	500 x 1162 x 560	500 x 1162 x 560	500 x 1162 x 560	560 x 1350 x 623	560 x 1350 x 623
Packing	in		22 ⁵ / ₆ x 47 ⁵ / ₈ x 25 ³ / ₅	22 ⁵ / ₆ x 47 ⁵ / ₈ x 25 ³ / ₅	22 ⁵ / ₆ x 47 ⁵ / ₈ x 25 ³ / ₅	22 ⁵ / ₆ x 47 ⁵ / ₈ x 25 ³ / ₅	22 ⁵ / ₆ x 47 ⁵ / ₈ x 25 ³ / ₅	28 x 54 ³ / ₄ x 25 ¹ / ₅	28 x 54 ³ / ₄ x 25 ¹ / ₅
	mm		580 x 1210 x 650	580 x 1210 x 650	580 x 1210 x 650	580 x 1210 x 650	580 x 1210 x 650	710 x 1390 x 640	710 x 1390 x 640
Weight (net/gross)	lbs		123/134	130/141	132/143	134/146	137/148	176/190	176/190
	kg		56/61	59/64	60/65	61/66	62/67	80/86	80/86
Shipping per STD 20/40/40HQ			30/60/120	30/60/120	30/60/120	30/60/120	30/60/120	27/54/54	27/54/54

Electrical	Unit	HAH14018	HAH14024	HAH14030	HAH14036	HAH14042	HAH14048	HAH14060
Outdoor Power Supply	V/Ph/Hz	208~230V/1N/60Hz	208~230V/1N/60Hz	208~230V/1N/60Hz	208~230V/1N/60Hz	208~230V/1N/60Hz	208~230V/1N/60Hz	208~230V/1N/60Hz

Fan Motor	Unit	HAH14018	HAH14024	HAH14030	HAH14036	HAH14042	HAH14048	HAH14060
Brand		Kangbao	Kangbao	Kangbao	Kangbao	Kangbao	Kangbao	Kangbao
Type		AC	AC	AC	AC	AC	AC	AC
Input	W	180	206	288	398	463	578	578
Output	W	100	135	180	220	270	300	300
Capacitor	μF	6	6	6	10	10	12	12
Speed (Lo/Mi/Hi)	rpm	340/390/440	490/530/570	530/600/670	690/730/805	610/723/839	820/870/920	820/870/920

Blower Specs	Unit	HAH14018	HAH14024	HAH14030	HAH14036	HAH14042	HAH14048	HAH14060
Diameter	in	12 ⁵ / ₁₆	12 ⁵ / ₁₆	12 ⁵ / ₁₆	12 ⁵ / ₁₆	12 ⁵ / ₁₆	12 ⁵ / ₁₆	12 ⁵ / ₁₆
Width	in	12 ²⁹ / ₃₂	12 ²⁹ / ₃₂	12 ²⁹ / ₃₂	12 ²⁹ / ₃₂	12 ²⁹ / ₃₂	12 ²⁹ / ₃₂	12 ²⁹ / ₃₂

Coil	Unit	HAH14018	HAH14024	HAH14030	HAH14036	HAH14042	HAH14048	HAH14060
Number of Rows		3(row) x 2(piece)	4(row) x 2(piece)	4(row) x 2(piece)	4(row) x 2(piece)	4(row) x 2(piece)	5(row) x 2(piece)	5(row) x 2(piece)
Tube pitch (a) x row pitch (b)	in	0.83 x 0.53	0.83 x 0.53	0.83 x 0.53	0.83 x 0.53	0.83 x 0.53	0.83 x 0.53	0.83 x 0.53
Fin Spacing	in	1/16	1/16	1/16	1/16	1/16	1/16	1/16
Fin Material		Hydrophilic	Hydrophilic	Hydrophilic	Hydrophilic	Hydrophilic	Hydrophilic	Hydrophilic
Tube Outside Diameter	in	0.276	0.276	0.276	0.276	0.276	0.276	0.276
Tube Material		inner grooved	inner grooved	inner grooved	inner grooved	inner grooved	inner grooved	inner grooved
Coil (L x H x W)	in	17 ⁷ / ₁₆ x 14 ⁷ / ₈ x 1 ³⁷ / ₆₄	17 ⁷ / ₁₆ x 16 ¹⁷ / ₃₂ x 2 ⁷ / ₆₄	17 ⁷ / ₁₆ x 16 ¹⁷ / ₃₂ x 2 ⁷ / ₆₄	17 ⁷ / ₁₆ x 16 ¹⁷ / ₃₂ x 2 ⁷ / ₆₄	17 ⁷ / ₁₆ x 16 ¹⁷ / ₃₂ x 2 ⁷ / ₆₄	19 ²⁷ / ₃₂ x 21 ¹ / ₂ x 2 ⁵ / ₈	19 ²⁷ / ₃₂ x 21 ¹ / ₂ x 2 ⁵ / ₈
Number of Circuit		6	8	8	8	8	12	12

Filter Specs	Unit	HAH14018	HAH14024	HAH14030	HAH14036	HAH14042	HAH14048	HAH14060
Size	in	18 x 20	18 x 20	18 x 20	18 x 20	18 x 20	20 x 22	20 x 22
	mm	457 x 508	457 x 508	457 x 508	457 x 508	457 x 508	508 x 559	508 x 559

PRODIRECT™
SERIES





BENEFITS & FEATURES

R410a environmentally friendly refrigerant.

Painted galvanized steel cabinet.

24V low voltage control.

AHRI Certified & ETL Listed.

Strong Scroll compressor with quick reactivity and stable operation.

Protective louvered steel coil guard.

Pressure and Temperature protection sensors to prevent damage.

Goldfin™ Corrosion protection.

Intelligent defrost programs that are automatic.

Condenser coils constructed with copper tubing and enhanced aluminum fins.

Wide operation temperature range.



Insulated cabinet

Galvanized steel with paint on all panels. Thermal insulator cover all inside panels to reduce heat and cooling losses and prevent condensed water accumulation.



Coil

"A" shape coils, constructed with copper tubing and enhanced aluminum fins.



Motor & Blower

Direct drive motors, 3-speed, provide selections of air flow to meet desired applications.



Expansion device

Use piston as expansion device



Filter optional

Detachable air filter for cleaning or renewal.



Multi-position installation

Versatile 4-way convertible design for upflow, downflow, and horizontal airflow.

PRODIRECT™ SPECIFICATIONS

INDOOR AIR HANDLER								
Model	Cooling Capacity (KBTu/h)	SEER	EER	External Static pressure(pa)	Air flow (CFM)	Net Dimension (WxHxD)(inch)	Packing Dimension (WxHxD)(inch)	Indoor Noise Level dB(A)
HAH14018	18.0	14	11.7	25	802/723/650	20x46x22	23x48x26	31-40
HAH14024	24.0	14	12.2	25	938/804/738	20x46x22	23x48x26	37-42
HAH14030	30.0	14	11.7	37	1204/1060/919	20x46x22	23x48x26	42-48
HAH14036	36.0	14	11.7	37	1376/1235/1161	20x46x22	23x48x26	47-51
HAH14042	42.0	14	11.7	37	1562/1385/1208	20x46x22	23x48x26	49-52
HAH14048	48.0	14	11.2	50	1695/1574/1434	22x54x25	26x55x28	51-54
HAH14060	56.5	14	11.2	50	1695/1574/1434	22x54x25	26x55x28	51-55

OUTDOOR UNIT									
Model	Cooling Capacity (KBTu/h)	SEER	EER	Net Dimension (WxHxD)(inch)	Liquid side (inch)	Gas side (inch)	Max. Refrigerant pipe length(ft)	Max. Difference in level(ft)	Indoor Noise Level dB(A)
HAC14018	18.0	14	11.7	22x25x22	Φ3/8	Φ3/4	82	33	57
HAC14024	24.0	14	12.2	22x25x22	Φ3/8	Φ3/4	82	33	60
HAC14030	30.0	14	11.7	29x33x29	Φ3/8	Φ3/4	82	33	60
HAC14036	34.5	14	11.7	29x33x29	Φ3/8	Φ3/4	82	33	60
HAC14042	42.0	14	11.7	29x33x29	Φ3/8	Φ3/4	82	33	60
HAC14048	48.0	14	11.2	29x33x29	Φ3/8	Φ7/8	82	33	63
HAC14060	57.0	14	11.2	29x33x29	Φ3/8	Φ7/8	82	33	63

Model	Cooling/Heating Capacity (KBTu/h)	SEER	EER	Net Dimension (WxHxD)(inch)	Liquid side (inch)	Gas side (inch)	Max. Refrigerant pipe length(ft)	Max. Difference in level(ft)	Indoor Noise Level dB(A)
HHP14018	17.6/16.0	14	11.7	22x25x22	Φ3/8	Φ3/4	82	33	60
HHP14024	23.4/22.0	14	12.2	22x25x22	Φ3/8	Φ3/4	82	33	60
HHP14030	28.6/27.6	14	11.7	29x33x29	Φ3/8	Φ3/4	82	33	61
HHP14036	34.0/33.8	14	11.7	29x33x29	Φ3/8	Φ3/4	82	33	61
HHP14042	40.5/44.0	14	11.7	29x33x29	Φ3/8	Φ3/4	82	33	63
HHP14048	46.0/46.0	14	11.2	29x33x29	Φ3/8	Φ7/8	82	33	63
HHP14060	56.5/55.0	14	11.2	29x33x29	Φ3/8	Φ7/8	82	33	63





48 Remington Way
Hickory, KY 42051

Phone: 270-366-0457
www.mrcool.com

***Display Images for demonstrative purposes only. Actual images during product use may vary.**

NOTICE: MRCOOL® products must be installed in accordance with all applicable local, state and federal codes and regulations. Unless explicitly stated otherwise, installation must be completed by a licensed / certified HVAC technician. ALL electrical connections to a power source must be performed by a licensed electrician and comply with local, state and federal electrical codes and regulations.





Limited Warranty



Models:

HAC14018, HAC14024, HAC14030, HAC14036, HAC14042, HAC14048, HAC14060, HHP14018, HHP14024, HHP14030, HHP14036, HHP14042, HHP14048, HAH14018, HAH14024, HAH14030, HAH14036, HAH14042, HAH14048, HAH14060

This non-transferable warranty provides for a total of 10 years of limited warranty coverage (Standard 5-year plus an additional 5-year extended parts and compressor warranty). Unless otherwise noted in the terms outlined in the following warranty, you must register your product at one of the following links to receive the additional 5 years of MRCOOL product warranty:

English: <https://mrcool.com/your-warranty/mrcool-minisplit-warranty-registration.html>

Espanol: <https://mrcool.com/your-warranty/spanish/mrcool-minisplit-warranty-registration.html>

This warranty applies only to units installed in owner-occupied residences. Units installed in buildings other than owner-occupied residences are separately warranted in either MRCOOL's Multi-Family Residence Warranty (if installed in a multi-family residence not occupied by the owner) or MRCOOL's Commercial Warranty (if installed in a non-residential building). For a copy of either the Multi-Family Residence Warranty or the Commercial Warranty, visit www.mrcool.com.

The unit models listed above, if installed in owner-occupied residences, are warranted by "MRCOOL" against defects in materials and workmanship under normal use and maintenance, as provided below:

To the original registered owner, MRCOOL provides a non-transferable warranty period of five (5) years on the compressor and five (5) years on all parts to the original end user. **An additional five (5) years limited warranty coverage on all parts and compressor is provided to the original end user when the product is registered online within 60 days of installation given the following conditions and limitations:**

This warranty does not continue after the unit is removed from the location where it was originally installed.

This warranty DOES NOT apply to, and no warranty is offered by MRCOOL on any unit that IS NOT purchased from an authorized dealer and installed with adherence to all applicable federal, state, and local codes, policies and licensing requirements.

The 5 year warranty period does not apply to any unit that is installed with a used and/or unapproved condenser / air handler. In such a case, this warranty in its entirety defaults to a period of **1 YEAR**.

The warranty period begins on the date of the original installation. If that date cannot be verified, the warranty period begins three months after the month of purchase.

As its only responsibility, and your only remedy, MRCOOL will furnish a replacement part, without charge for the part only, to replace any part that is found to be defective due to workmanship or materials under normal use and maintenance. For warranty credit, the defective part must be returned to a MRCOOL heating and air conditioning products distributor by a state or province certified or licensed contractor. Any part replaced pursuant to this warranty is warranted only for the unexpired portion of the warranty term applying to the original part.

This warranty does not apply to labor, freight, or any other cost associated with the service, repair or operation of the unit. MRCOOL will not pay for electricity or fuel costs, or increases in electricity or fuel costs, for any reason, including additional or unusual use of supplemental electric heat. This warranty does not cover lodging or labor charges. This warranty does not cover refrigerant.

MRCOOL is not responsible for:

1. Damage or repairs required as a consequence of faulty installation or application.
2. Damage as a result of floods, fires, winds, lightning, accidents, corrosive atmosphere or other conditions beyond the control of MRCOOL.
3. Damage or repairs required as a result of the use of components or accessories not compatible with this unit.
4. Units installed outside the United States or its territories, or Canada.
5. Normal maintenance as described in the installation and operating manual, such as cleaning of the coils, filter cleaning and/or replacement, and lubrication.
6. Parts or accessories not supplied or designated by MRCOOL.
7. Damage or repairs required as a result of any improper use, maintenance, operation or servicing.
8. Damage or failure to start due to interruption and/or inadequate electrical service.
9. Any damage caused by frozen or broken water pipes in the event of equipment failure.
10. Changes in the appearance of the unit that do not affect its performance.
11. Replacement of fuses and replacement or resetting of circuit breakers.
12. Units operated in incomplete structures.
13. Damage or repairs required as a result of the use of used or recycled refrigerant.

This warranty is provided in lieu of any and all other warranties, expressed or implied, including any implied warranty of merchantability and fitness for a particular purpose. Whether any claim is based on negligence or other tort, breach of warranty or other breach of contract, or any other theory, IN NO EVENT SHALL MRCOOL, LLC BE LIABLE FOR INCIDENTAL OR CONSEQUENTIAL DAMAGES TO ANY PERSONAL, INTANGIBLE, AND/OR REAL PROPERTY; NOR SHALL MRCOOL, LLC BE LIABLE FOR EXPENSES RESULTING FROM BUSINESS INTERRUPTION, INCLUDING BUT NOT LIMITED TO LOST PROFITS, EXTRA UTILITY COSTS OR OTHERWISE. Some states and provinces do not allow the exclusion or limitation of incidental or consequential damages, so the above exclusion may not apply to you.

For further information about this warranty visit mrcool.com