



Mr. Cool



MULTI-POSITION AIR HANDLER FOR
MAC16*A AND MHP15*A CONDENSERS

AIR HANDLER with TXV MAHM*TA



- ✓ Mobile Home Approved
- ✓ Energy Efficient
- ✓ Durable Build & Finish
- ✓ R-410A Refrigerant
- ✓ Multi-Position Application
- ✓ CoolGuard™ Corrosion Resistant Coil
- ✓ Superior Performance
- ✓ Compact Design

48 Remington Way
Hickory, KY 42051
270.366.0457

www.mrcool.com



Multi-Position Air Handler

for **MAC*16A** and **MHP15*A** Condensers

AIR HANDLER with TXV†

MAHM*TA

MAHM*CTA is up to 14.5 SEER (PSC motor)
MAHM*ETA is up to 16 SEER (ECM motor)

The MRCOOL® Multi-Position Air Handler's design delivers dependable comfort and is built for reliability. The electronically commutated motor (ECM) delivers consistent airflow throughout the seasons, allowing you to remain relaxed at all times. When choosing a MRCOOL® Multi-Position Air Handler, you can rest assured your choice is energy-efficient.

- Available in 1.5, 2, 2.5, 3, 3.5, 4, and 5 ton capacities.
- 10-Year Parts Limited Warranty.‡

†Warranty provides for a total of 10 years of limited warranty coverage (Standard 5-year limited parts warranty plus an additional 5-year limited extended parts warranty; 15-year for heat exchanger where specified). Warranty must be registered online within 60 days of installation to qualify for extended coverage. Unregistered equipment defaults to 5-year coverage.

SPECIFICATIONS

MODEL NO.	Unit	MAHM018CTA	MAHM024CTA	MAHM030CTA	MAHM036CTA	MAHM042CTA	MAHM048CTA	MAHM060CTA
Power Supply	Ph-V-Hz	1-208/230 - 60	1-208/230 - 60	1-208/230 - 60	1-208/230 - 60	1-208/230 - 60	1-208/230 - 60	1-208/230 - 60
Blower Motor	Type	PSC	PSC	PSC	PSC	PSC	PSC	PSC
	Rated HP	HP	1/5	1/3	1/2	1/3	1/2	1
	Size	inch	9 x 6	9 x 6	10 x 8	10 x 8	10 x 8	12 x 10
Filter Size	inch	15 x 20	15 x 20	15 x 20	18 x 20	18 x 20	18 x 20	18 x 20
Max Elec. Heat Available	kW	7.5	10	15	15	15	20	20
Indoor Unit	Dimension (WxHxD)	inch	18.5 x 43.5 x 16.5	18.5 x 45.5 x 16.5	18.5 x 47 x 16.5	21.25 x 53.63 x 19.5	21.25 x 53.63 x 19.5	21.25 x 55 x 19.5
	Packing (WxHxD)	inch	27 x 47 x 22.8	27 x 49 x 22.8	27 x 50.5 x 22.8	27 x 57.5 x 25.5	27 x 57.5 x 25.5	27 x 58.5 x 25.5
	Weight	lbs	109	127	133	163	168	186
Connection Liq./Suct.	inch	3/8"-3/4"	3/8"-3/4"	3/8"-3/4"	3/8"-7/8"	3/8"-7/8"	3/8"-7/8"	3/8"-7/8"

MODEL NO.	Unit	MAHM024ETA	MAHM030ETA	MAHM036ETA	MAHM042ETA	MAHM048ETA	MAHM060ETA
Power Supply	Ph-V-Hz	1-208/230 - 60	1-208/230 - 60	1-208/230 - 60	1-208/230 - 60	1-208/230 - 60	1-208/230 - 60
Blower Motor	Type	ECM	ECM	ECM	ECM	ECM	ECM
	Rated HP	HP	1/2	1/2	1/2	3/4	1
	Size	inch	10 x 8	10 x 8	10 x 8	12 x 10	12 x 10
Filter Size	inch	15 x 20	15 x 20	15 x 20	18 x 20	18 x 20	18 x 20
Max Elec. Heat Available	kW	10	15	15	15	20	20
Indoor Unit	Dimension (WxHxD)	inch	18.5 x 45.5 x 16.5	18.5 x 47 x 16.5	21.5 x 53.63 x 19.5	21.5 x 53.63 x 19.5	21.5 x 55 x 19.5
	Packing (WxHxD)	inch	27 x 49 x 22.8	27 x 50.5 x 22.8	27 x 57.5 x 25.5	27 x 57.5 x 25.5	27 x 58.5 x 25.5
	Weight	lbs	127	133	163	168	186
Connection Liq./Suct.	inch	3/8"-3/4"	3/8"-3/4"	3/8"-7/8"	3/8"-7/8"	3/8"-7/8"	3/8"-7/8"



The Signature Series is **NOT** designed for amateur installation. Installation **SHOULD** be performed by an authorized technician. Please read this manual carefully before installation and keep it for future reference.

Owner & Installation Manual



MRCOOL®

COMFORT MADE SIMPLE

Signature Series

MAHM*ETA AIR Handler

The Signature Series is **NOT** designed for amateur installation. Installation **SHOULD** be performed by an authorized technician. Please read this manual carefully before installation and keep it for future reference.

INSTALLATION INSTRUCTIONS

MAHM*ETA Series Air Handler

This manual must be left with the homeowner for future reference.



This is a safety alert symbol and should never be ignored. When you see this symbol on labels or in manuals, be alert to the potential for personal injury or death.



Table of Contents

MAH*E Unit Dimensions – Upflow – Inches (mm).....	2
Shipping and Packing List	3
General.....	3
Requirements	3
Installation Clearances	4
Installation	4
Condensate Drain.....	6
Duct System and Filters	8
Brazing Refrigerant Lines	9
Sealing the Unit	11
Electrical Connections	11
Blower Performance Data	15
Air Flow - Cooling Blower Speed.....	16
Operation Inspection	16
Operation.....	17
Maintenance.....	17
Professional Maintenance	17
Cabinet Insulation.....	18
Use of Air Handler During Construction.....	18

WARNING

Improper installation, adjustment, alteration, service or maintenance can cause property damage, personal injury or loss of life. Installation and service must be performed by a licensed professional HVAC installer or equivalent, service agency, or the gas supplier.

CAUTION

As with any mechanical equipment, contact with sharp sheet metal edges can result in personal injury. Take care while handling this equipment and wear gloves and protective clothing.

IMPORTANT

The Clean Air Act of 1990 bans the intentional venting of refrigerant (CFCs, HCFCs and HFCs) as of July 1, 1992. Approved methods of recovery, recycling or reclaiming must be followed. Fines and/or incarceration may be levied for noncompliance.

Manufactured By
MRCOOL LLC
Hickory, KY 42051

P507788-01C
(P) 507788-01C

Save these instructions for future reference

MAHM*ETA Unit Dimensions – Upflow – Inches (mm)

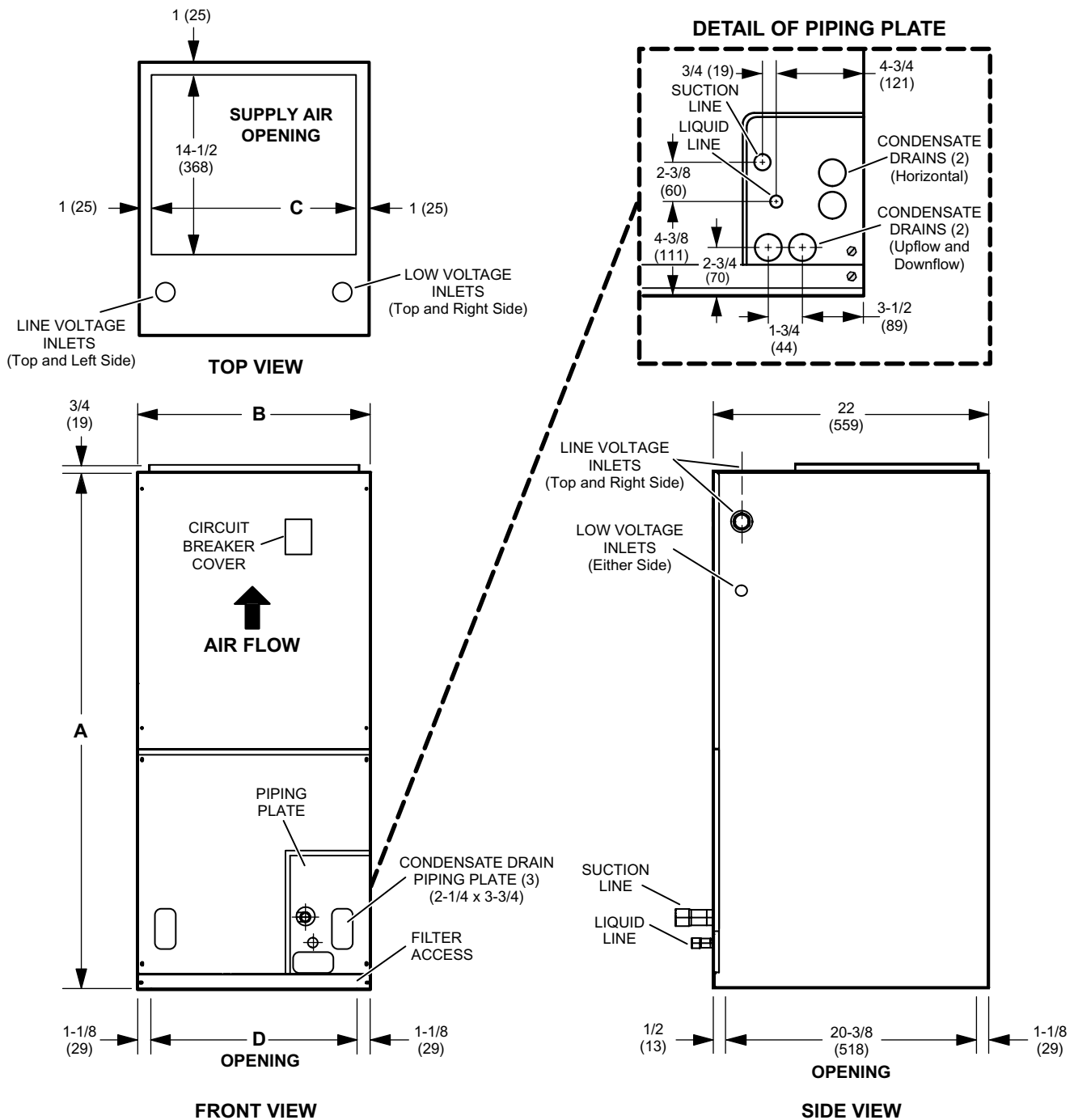

NOTE: Unit is shipped configured for horizontal right-hand air discharge. Unit may be converted to horizontal left-hand air discharge by repositioning horizontal drain pan. Dimensions remain the same in all configurations.

Dimensions	024		030		036 / 042		048		060	
	in.	mm	in.	mm	in.	mm	in.	mm	in.	mm
A	45-1/2	1156	47	1194	53-5/8	1362	55	1397	59-3/4	1518
B	18-1/2	470	18-1/2	470	21-1/2	546	21-1/2	546	21-1/2	546
C	16-1/2	419	16-1/2	419	19-1/2	495	19-1/2	495	19-1/2	495
D	16-1/4	413	16-1/4	413	19-1/4	489	19-1/4	489	19-1/4	489

Shipping and Packing List

Package 1 of 1 contains:

1 – Assembled air handler unit factory-equipped for upflow or horizontal air discharge application (includes upflow and horizontal drain pans and pre-installed air filter).

Check the air handler for shipping damage; if found, immediately contact the last carrier. Check the unit rating plate to confirm that delivered unit matches order.

General

The MAHM*ETA series air handler with all-aluminum coil is designed for indoor installation only. As shipped, the unit is ready for installation in either upflow or horizontal right-hand air discharge applications. Horizontal drain pan may be repositioned in the field to allow installation in the horizontal left-hand air discharge position. Various accessories are available and listed in the MAHM*ETA Product Specification for ordering.

This instruction is intended as a general guide and does not supersede local or national codes in any way. Consult authorities having jurisdiction before installation.

NOTE: *Special procedures are required for cleaning the all-aluminum coil in this unit. See Page 17 in this instruction for information.*

Requirements

WARNING

Excessive Weight Hazard - Use two or more people when moving and installing the unit. Failure to do so can result in back or other type of injury.

IMPORTANT

MAHM*ETA units include a factory-installed check/expansion valve which will provide optimal refrigerant control and system performance with outdoor units of varying capacities. These units must be installed as a part of a matched system as outlined in the MAHM*ETA Product Specification.

These instructions are intended as a general guide and do not supersede local or national codes in any way. Consult authorities having jurisdiction before installation.

Compliance with all local, state, or national codes pertaining to this type of equipment should be determined prior to installation. Read this instruction manual, as well as the instructions supplied in separate equipment, before starting the installation.

In addition to conforming to manufacturer's installation instructions and local municipal building codes, installation of air handler units (with or without optional electric heat), MUST conform with National Fire Protection Association (NFPA) standards: "Standard for Installation of Air Conditioning and Ventilation Systems" (NFPA No. 90A) and "Standard for Installation of Residence Type Warm Air Heating and Air Conditioning Systems" (NFPA No. 90B).

All models are designed for indoor installation only. The installation of the air handler, field wiring, duct system, etc. must conform to the requirements of the National Electrical Code, ANSI/NFPA No. 70 (latest edition) in the United States, and any state laws, and local ordinances (including plumbing or waste water codes).

Local authorities having jurisdiction should be consulted before installation is made. Such applicable regulations or requirements take precedence over the general instructions in this manual.

Install the conditioned air plenum, ducts and air filters (provided) in accordance with NFPA 90B Standard for the Installation of Warm Air Heating and Air-Conditioning Systems (latest edition).

The air handler is shipped from the factory completely assembled. The unit is provided with flanges for the connection of the duct system.

Do not remove the cabinet knockouts until it has been determined which knockouts will need to be removed for the installation.

Select the air discharge position which best suits the site conditions. Consider required clearances, space, routing requirements for refrigerant line, condensate disposal, filters, duct system, wiring, and accessibility for service. Refer to the rating plate on the air handler for specific information.

WARNING



Danger of explosion. Keep flammable materials and vapors, such as gasoline, away from air handler. Place air handler so that heating elements are at least 18 inches (46 cm) above the floor for a garage installation. Failure to follow these instructions can result in death, explosion, or fire.

⚠ IMPORTANT

Excessive condensation may occur if the unit is installed in a warm, humid place. When the unit is installed in an unconditioned space, apply sealant around electrical wires, refrigerant piping and condensate lines at the point where they enter the cabinet.

Apply sealant on the inside of the cabinet at the point where the electrical wires exit through the conduit opening. This will also keep warm and moist unconditioned air out of the air handler cabinet where it will form condensate on the cooler control box and electrical controls.

⚠ IMPORTANT

This unit is approved for installation clearance to combustible material as stated on the unit rating plate. Accessibility and service clearances must take precedence over combustible material clearances.

The air handler must be installed so that free access is allowed to the coil/filter compartment and blower/control compartment.

NOTE: *During cooling operation, excessive sweating may occur if the air handler is installed in a warm and humid space.*

NOTE: *If installed in an unconditioned space, sealant should be applied around the electrical wires, refrigerant tubing, and condensate lines where they enter the cabinet.*

NOTE: *Electrical wires should be sealed on the inside where they exit the conduit opening. Sealant is required to prevent air leakage into, and condensate from forming inside of, the air handler, the control box, and on the electrical controls.*

NOTE: *This unit is approved for installation clearance to combustible material as stated on the unit rating plate. Accessibility and service clearances must take precedence over combustible material clearances.*

NOTE: *The air handler must be installed so that free access is allowed to the coil/filter compartment and blower/control compartment.*

Installation Clearances

Non-Ducted Return Closet Installation

The air handler can be installed in a closet with a false bottom to form a return air plenum. It may also be installed with a return air plenum under the air handler.

Louvers or return air grilles are field-supplied. Local codes may limit application of systems without a ducted return to single-story buildings.

When a MAHM*ETA unit is installed in a closet with a louvered return opening, the minimum open area for the louvers will be:

- 320 square inches for -024 models;
- 360 square inches for -030 and -036 models;
- 450 square inches for -042 thru -060 models

If the free area is not known, assume a 25% free area for wood or a 75% free area for metal louvers or grilles. Using the louver dimensions and the 25% or 75% assumption, determine if the open area meets the minimum open area listed above.

If a return air plenum is used, the return air grille should be immediately in front of the opening in the plenum to allow for the free flow of return air. When not installed in front of the opening, there must be adequate clearance around the air handler to allow for the free flow of return air.

Installation

Each unit consists of a blower assembly, refrigerant coil, and controls in an insulated galvanized steel factory-finished enclosure. Knockouts are provided for electrical wiring entrance.

For ease in installation, it is best to make any necessary coil configuration changes before setting air handler in place.

Refrigerant Metering Device

MAHM*ETA units are equipped with a factory-installed expansion valve with internal check valve for cooling or heat pump application.

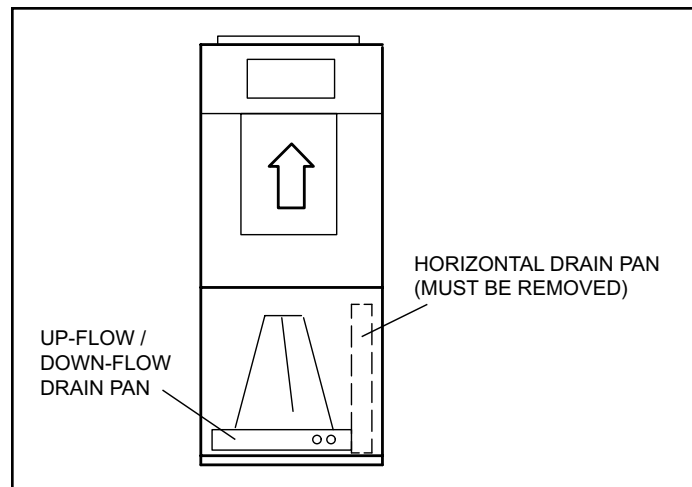

Figure 1. Upflow Configuration

Upflow Application

1. The air handler must be supported on the bottom only and set on solid floor or field-supplied support frame. Securely attach the air handler to the floor or support frame.
2. If installing a unit in an upflow application, remove the horizontal drain pan.

NOTE: *The horizontal drain pan is not required in upflow air discharge installations; its removal provides the best efficiency and air flow.*

3. Place the unit in the desired location and slope unit. Connect return and supply air plenums as required using sheet metal screws.
4. Install units that have no return air plenum on a stand that is at least 14" from the floor. This will allow proper air return.

Horizontal Applications

⚠ IMPORTANT

When removing the coil, there is a possibility of danger of equipment damage and personal injury. Be careful when removing the coil assembly from a unit installed in right- or left-hand applications. The coil may tip into the drain pan once it is clear of the cabinet. Support the coil when removing it..

NOTE: *When the unit is installed in horizontal applications, a secondary drain pan is recommended. Refer to local codes.*

NOTE: *This unit may be installed in left-hand or right-hand air discharge horizontal applications. Adequate support must be provided to ensure cabinet integrity. Ensure that there is adequate room to remove service and access panels if installing in the horizontal position.*

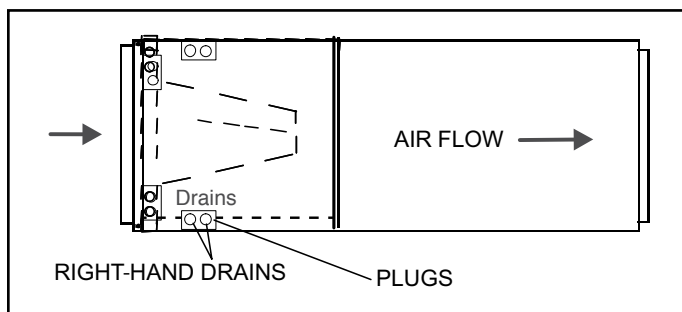

Figure 2. Right-Hand Discharge Configuration

Right-Hand Discharge

1. Determine which plugs are required for drain line connections.
2. With access door removed, remove drain line plugs to install drain lines.

3. Set unit so that it is sloped toward the upflow drain pan end of the unit and level from front to back of unit (see Figure 7).
4. The horizontal configuration is shown in Figure 2.
5. If the unit is suspended, the entire length of the cabinet must be supported. If you use a chain or strap, use a piece of angle iron or sheet metal attached to the unit (either above or below) to support the length of the cabinet. Use securing screws no longer than 1/2 inch to avoid damaging the coil or filter. See Figure 3. Use sheet metal screws to connect the return and supply air plenums as required.

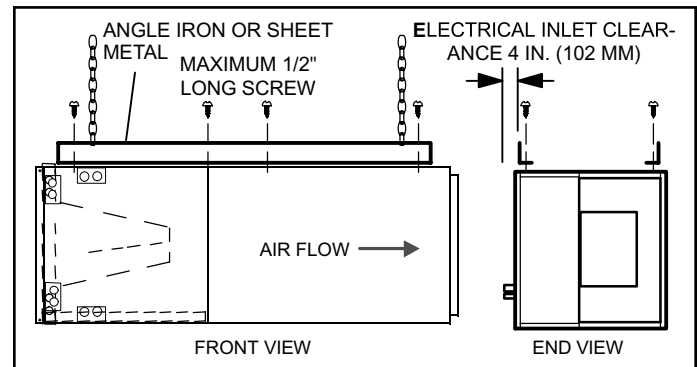

Figure 3. Suspending Horizontal Unit

Left-Hand Air Discharge

For horizontal left-hand air discharge, the following field modifications are required.

1. Remove access panels and the corrugated padding between the blower and coil assembly. Discard the corrugated padding.
2. Pull the coil assembly from unit. Pull off the horizontal drain pan.
3. Remove the drain plugs from back drain holes on horizontal drain pan and reinstall them on front holes.

⚠ IMPORTANT

After removal of drain pan plug(s), check drain hole(s) to verify that drain opening is fully open and free of any debris. Also check to make sure that no debris has fallen into the drain pan during installation that may plug up the drain opening.

4. Rotate drain pan 180° front-to-back and install it on the opposite side of the coil.
5. Remove screws from top cap.
6. Remove plastic plug from left hole on coil front end seal and reinstall plug in back hole.

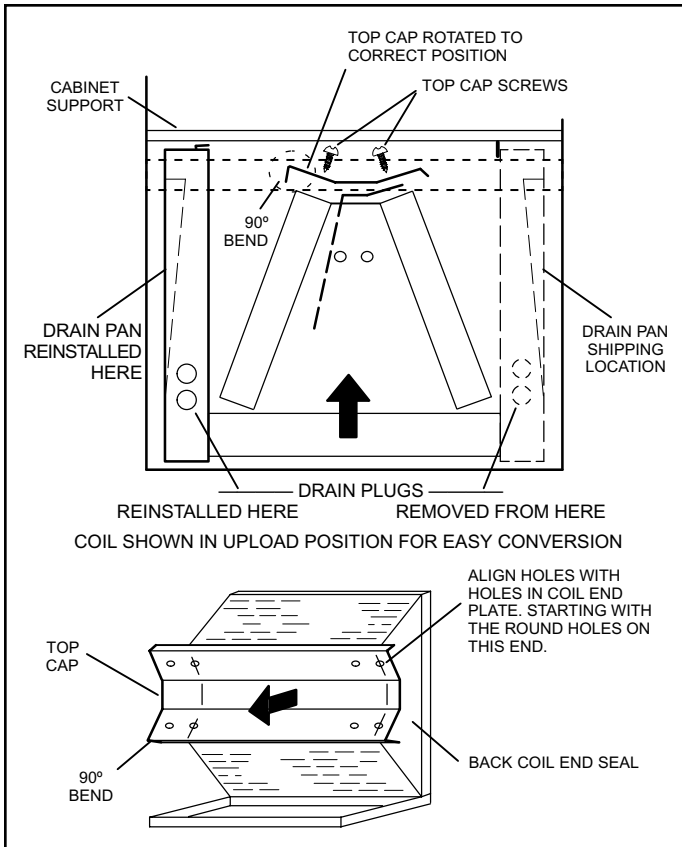

Figure 4. Field Modification for Left-Hand Discharge

7. Rotate top cap 180° front-to-back and align with unused screw holes. Holes must align with front and back coil end plates. The top cap has a 45° bend on one side and a 90° bend on the other. The 90° bend must be on the same side as the horizontal drain pan as illustrated in Figure 4.

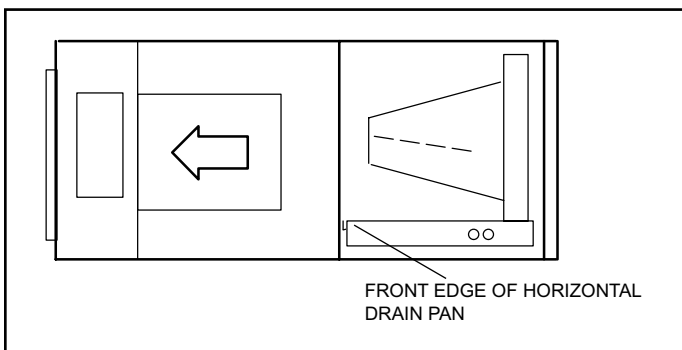

Figure 5. Left-Hand Discharge Configuration

NOTE: Be very careful when reinstalling the screws into the coil end plate engaging holes. Misaligned screws may damage the coil.

8. From the upflow position, flip cabinet 90° to the left and set into place. Replace blower assembly. Secure coil in place by bending down the tab on the cabinet support rail as illustrated.

NOTE: Seal around the exiting drain pipe, liquid and suction lines to prevent infiltration of humid air.

9. Flip access door and replace it on the unit.
10. Set unit so that it is sloped 1/4" toward the drain pan end of the unit. Connect return and supply air plenums as required using sheet metal screws.
11. If suspending the unit, it must be supported along the entire length of the cabinet. If using chain or strap, use a piece of angle iron or sheet metal attached to the unit (either above or below) so that the full length of the cabinet is supported. Use securing screws no longer than 1/2" to avoid damage to coil or filter, as illustrated in Figure 3. Connect return and supply air plenums as required using sheet metal screws.

Downflow Application

NOTE: If downflow application is required, separately order kit number 83M57 and install per kit's instructions. Also use metal or class I supply and return air plenums. Use the installation instruction provided with the downflow kit.

! IMPORTANT

If electric heat section with circuit breakers (ECBA25) is installed in a MAHM*ETA unit in a downflow application, the circuit breakers must be rotated 180° to the UP position. See ECBA25 installation instructions for more details.

Condensate Drain

! IMPORTANT

On units of this type, where the blower "draws" rather than "blows" air through the coil, traps must be installed in the condensate drain lines (primary and auxiliary, if used). Traps prevent the blower from drawing air through the drain lines into the air supply.

! IMPORTANT

A field-fabricated secondary drain pan, with a drain pipe to the outside of the building, is required in all installations over a finished living space or in any area that may be damaged by overflow from the main drain pan. In some localities, local codes may require a secondary drain pan for any horizontal installation.

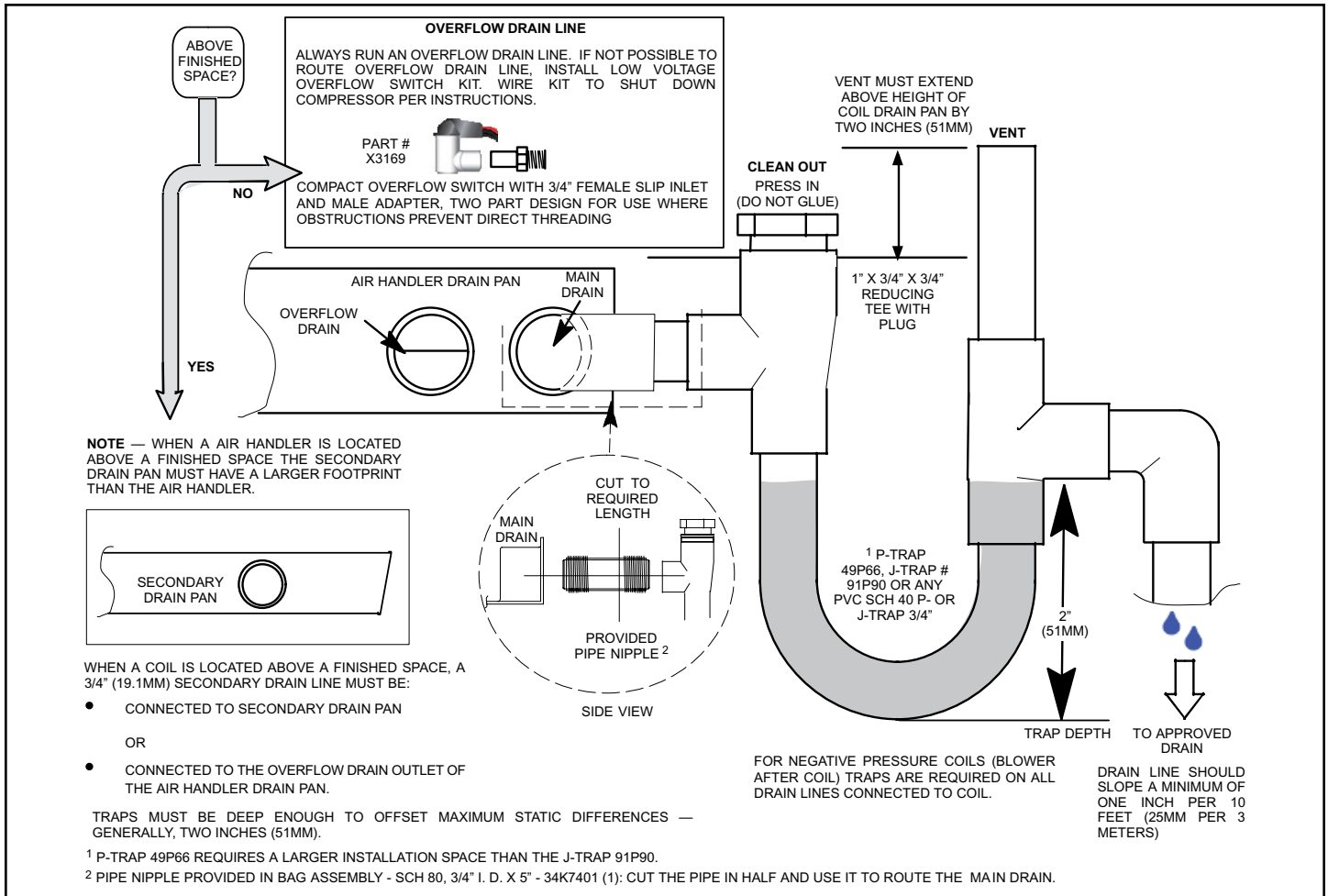

Figure 6. Typical Main and Overflow Drain

Sloping The Unit

Make sure the unit is sloped (similar to the slope shown in Figure 7) so that the drain pan will empty completely without water standing in the pan.

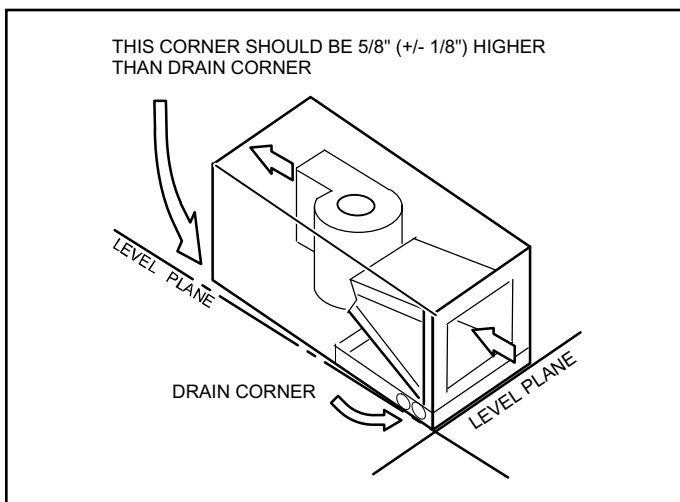

Figure 7. Sloping the Unit for Proper Drainage

Install Condensate Drain

The air handler is provided with 3/4" NPT condensate drain connections.

⚠ IMPORTANT

On some pans, the primary and secondary drain holes have knockouts.

Confirm primary and secondary drains are open.

1. MAHM*ETA units are equipped with a drain pan, which includes green (main drain) and red (secondary drain) plugs. Unscrew the plugs to remove them before inserting condensate drain fittings.

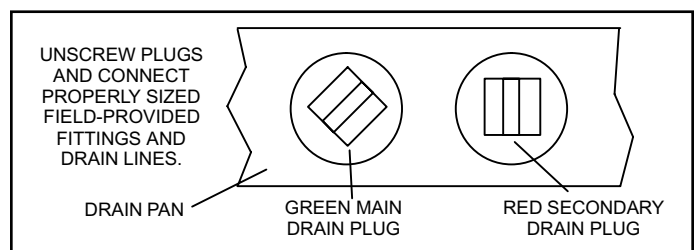

Figure 8. Drain Line Connections

2. Install properly sized, field-provided connection fittings and connect primary drain line to the main drain pan connection.

NOTE: *When installing drain line connection fittings to the drain pan, hand tighten the fitting and use a thread sealant. Over-tightening the fittings can split connections on the drain pan.*

3. If the secondary drain line is to be used, remove the plug or the knockout and route the drain line so that water draining from the outlet will be easily noticed by the homeowner. Refer to local codes for drain trap requirements on the secondary drain line.
4. Check again to ensure drain ports and drain pan are free of all debris.
5. Plug and check any unused drain pan openings for tightness. Torque plugs to 36 in. lb. to prevent water leaks or seepage from the drain pan.
6. Install a 2" trap in the main (primary) drain lines as close to the unit as practical (see Figure 6). Make sure the top of the trap is below the connection to the drain pan to allow complete drainage of the pan.

NOTE: *Horizontal runs must have an anti-siphon air vent (standpipe) installed ahead of the horizontal run. See Figure 6. An extremely long horizontal run may require an oversized drain line to eliminate air traps.*

NOTE: *Do not operate air handler without a trap in the main (primary) drain. The condensate drain is on the negative pressure side of the blower; therefore, air being pulled through the condensate line will not allow positive drainage without a proper trap.*

7. Route the drain line to the outside or to an appropriate drain. Drain lines must be installed so they do not block service access to the front of the air handler. A 24" clearance is required for filter, coil, or blower removal and service access.

NOTE: *Check local codes before connecting the drain line to an existing drainage system. Insulate the drain lines where sweating could cause water damage.*

Test Condensate Drain

Test the drain pan and drain line after installation:

1. Pour several quarts of water into drain pan. Use enough water to fill both the drain trap and the line.
2. Check the installed drain pan. Drain pan must be draining completely. Drain line fittings must not be leaking. Water must be draining from the end of the primary drain line.
3. Correct any leaks found.

Duct System and Filters

Duct System

The air handler is provided with flanges for the connection of the supply plenum.

Supply and return duct system must be adequately sized to meet the system's air requirements and static pressure capabilities. The duct system should be insulated with a minimum of 1" thick insulation with a vapor barrier in conditioned areas or 2" minimum in unconditioned areas.

Supply plenum should be the same size as the flanged opening provided around the blower outlet and should extend at least 3 ft. from the air handler before turning or branching off plenum into duct runs. The plenum forms an extension of the blower housing and minimizes air expansion losses from the blower.

Filters

A filter is provided. Table 1 lists the filter size for each unit.

Model	Filter Size – in.
-024, -030	15" x 20" x 1"
-036, -042, -048, -060	18" x 20" x 1"

Table 1. Unit Air Filter Size Chart

IMPORTANT

If a high efficiency filter is being installed as part of this system to ensure better indoor air quality, the filter must be properly sized. High efficiency filters have a higher static pressure drop than standard efficiency glass/foam filters. If the pressure drop is too great, system capacity and performance may be reduced. The pressure drop may also cause the limit to trip more frequently during the winter and the indoor coil to freeze in the summer, resulting in an increase in the number of service calls. Before using any filter with this system, check the specifications provided by the filter manufacturer against the data given in the appropriate Product Specifications. Additional information is provided in Service and Application Note ACC002 (August 2000).

Installing Duct System

Connect supply air duct to the flange on top of the air handler. If an isolation connector is used, it must be nonflammable.

Field-Fabricated Return Air Duct Flange For Horizontal Applications

A return air duct system is recommended, but not factory-provided. If the unit is installed in a confined space or closet, run a full-size return connection to a location outside the closet.

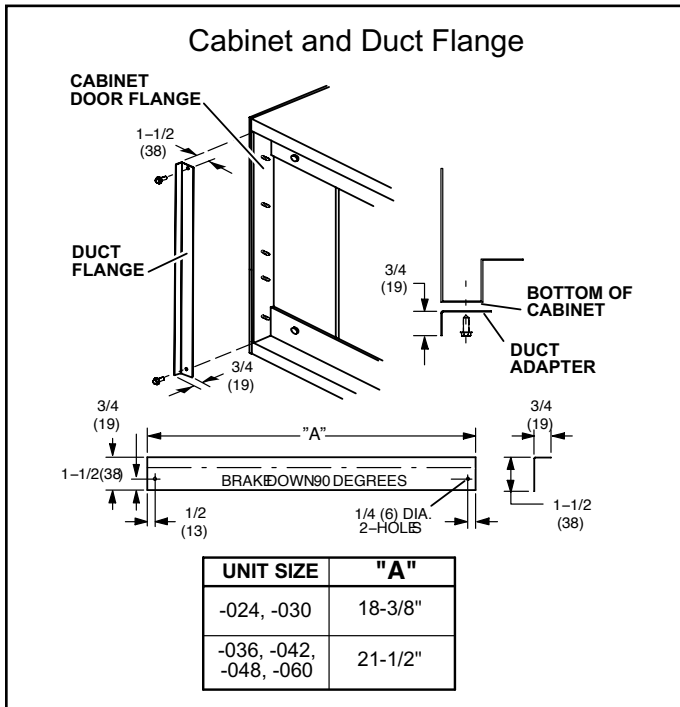

Figure 9. Cabinet and Duct Flange

Brazing Refrigerant Lines

Refrigerant lines must be connected by a qualified technician in accordance with established procedures.

IMPORTANT

Refrigerant lines must be clean, dry, refrigerant-grade copper lines. Air handler coils should be installed only with specified line sizes for approved system combinations.

Handle the refrigerant lines gently during the installation process. Sharp bends or kinks in the lines will cause a restriction.

Do not remove the caps from the lines or system connection points until connections are ready to be completed.

WARNING

Polyol ester (POE) oils used with HFC-410A refrigerant absorb moisture very quickly. It is very important that the refrigerant system be kept closed as much as possible. **DO NOT** remove line set caps or service valve stub caps until you are ready to make connections.

WARNING



When using a high pressure gas such as nitrogen to pressurize a refrigeration or air conditioning system, use a regulator that can control the pressure down to 1 or 2 psig (6.9 to 13.8 kPa).

WARNING



Danger of fire. Bleeding the refrigerant charge from only the high side may result in pressurization of the low side shell and suction tubing. Application of a brazing torch to a pressurized system may result in ignition of the refrigerant and oil mixture. Check the high and low pressures before applying heat.

CAUTION

Brazing alloys and flux contain materials which are hazardous to your health.

Avoid breathing vapors or fumes from brazing operations. Perform operations only in well-ventilated areas.

Wear gloves and protective goggles or face shield to protect against burns.

Wash hands with soap and water after handling brazing alloys and flux.

IMPORTANT

To prevent the build-up of high levels of nitrogen when purging, it must be done in a well-ventilated area. Purge low-pressure nitrogen (1 to 2 psig) through the refrigerant piping during brazing. This will help to prevent oxidation and the introduction of moisture into the system.

NOTE: Recommended line length is 50' or less. If more than 50' line set is required, contact MRCOOL.

1. Route the suction and liquid lines from the fittings on the indoor coil to the fittings on the outdoor unit. Run the lines in a direct path, avoiding unnecessary turns and bends.
2. Make sure that the suction line is insulated over the entire exposed length and that neither suction nor liquid lines are in direct contact with floors, walls, duct system, floor joists, or other piping.

PLEASE READ IMPORTANT ISSUES CONCERNING BRAZING OPERATIONS IN THE BRAZING REFRIGERANT LINES SECTION BEFORE PROCEEDING.

NOTE - REFER TO OUTDOOR UNIT INSTALLATION INSTRUCTIONS FOR REFRIGERANT PIPING SIZE REQUIREMENTS.

NOTE - Use silver alloy brazing rods with five or six percent minimum silver alloy for copper-to-copper brazing, 45 percent alloy for copper-to-brass and copper-to-steel brazing.

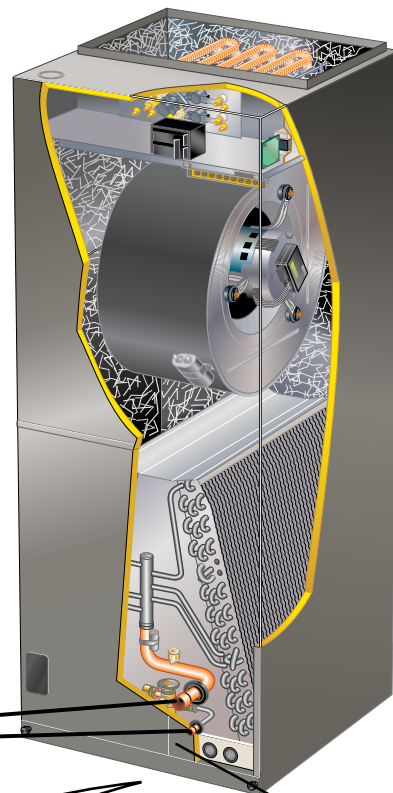

A REMOVE ACCESS PANEL

B REMOVE RUBBER PLUG FROM BOTH LIQUID AND SUCTION LINES

NOTE - MAHMETASERIES UNITS USE NITROGEN OR DRY AIR AS A HOLDING CHARGE. IF THERE IS NO PRESSURE WHEN THE RUBBER PLUGS ARE REMOVED, CHECK THE COIL FOR LEAKS BEFORE INSTALLING.

C EITHER REMOVE OR PUSH PIPE WRAPPING BACK THROUGH HOLE IN PIPING PLATE BEFORE LINE SET CONNECTION AND BRAZING.

D CONNECT PIPES

NOTE - REFRIGERANT LINE SETS SHOULD BE ROUTED TO ALLOW FILTER ACCESSIBILITY.

E CONNECT GAUGES AND START NITROGEN FLOW

FLOW REGULATED NITROGEN (AT 1 TO 2 PSIG) THROUGH THE REFRIGERATION GAUGE SET INTO THE VALVE STEM PORT CONNECTION ON THE OUTDOOR UNIT LIQUID LINE SERVICE VALVE AND OUT OF THE VALVE STEM PORT CONNECTION ON THE SUCTION SERVICE VALVE.

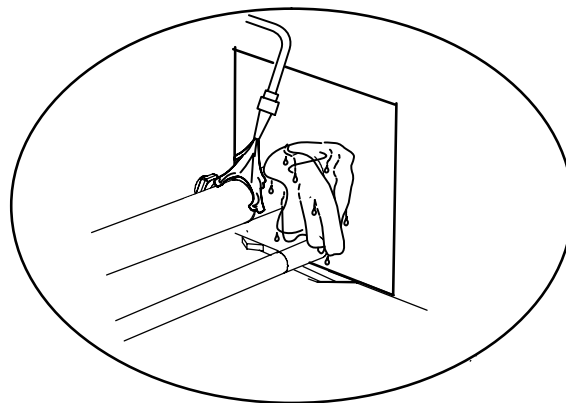
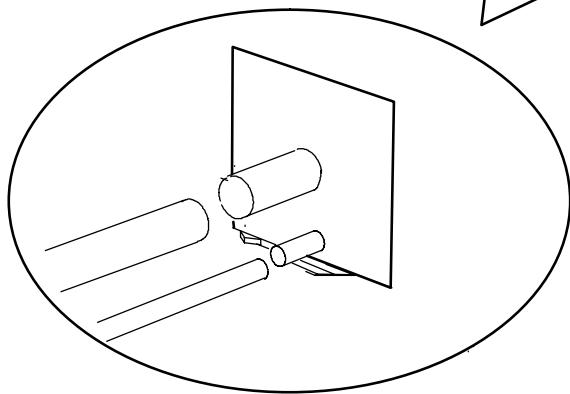

F PLACE A WET RAG AGAINST PIPING PLATE AND AROUND THE SUCTION LINE CONNECTION.

G BRAZE CONNECTION. ALLOW PIPE TO COOL BEFORE REMOVING WET RAG FROM CTXV SENSING BULB AND PIPING PANEL AREA.

H REPEAT PREVIOUS PROCEDURE FOR LIQUID LINE.

REFER TO INSTRUCTIONS PROVIDED WITH OUTDOOR UNIT FOR LEAK TESTING, EVACUATING AND CHARGING PROCEDURES

Figure 10. Brazing Connections

- To avoid damaging the rubber grommets in the cabinet while brazing, slide the rubber grommets over the refrigerant lines until they are away from the heat source.

NOTE: Place wet rags against piping plate and around suction line connections.

- Connect the suction and liquid lines to the evaporator coil. Take care to protect the cabinet and internal components as detailed in Figure 10.
- Braze using an alloy of silver or copper and phosphorus with a melting point above 1,100°F (593°C).

NOTE: Do not use soft solder.

- Allow refrigerant pipes to cool to room temperature.

NOTE: Make sure to route copper refrigerant tubing away from sharp edges and make sure that it does not touch other metal surfaces. This prevents damage caused by vibration or metal-on-metal contact.

- Reinstall the rubber grommets into the refrigerant piping panel.

NOTE: Make sure expansion valve capillary tube is not touching metal edges or copper tubing.

- Make sure outdoor unit has been placed according to the Installation Instructions and is connected to the refrigerant lines

Sealing the Unit

Seal the unit so that warm air is not allowed into the cabinet. Warm air introduces moisture, which results in water blow-off problems. This is especially important when the unit is installed in an unconditioned area.

If installed in an unconditioned space, sealant should be applied around the electrical wires, refrigerant tubing, and condensate lines where they enter the cabinet.

WARNING

There must be an airtight seal between the bottom of the air handler and the return air plenum. Use fiberglass sealing strips, caulking, or equivalent sealing method between the plenum and the air handler cabinet to ensure a tight seal. Return air must not be drawn from a room where this air handler or any gas-fueled appliance (i.e., water heater), or carbon monoxide-producing device (i.e., wood fireplace) is installed.

IMPORTANT

Use duct tape and/ or Permagem to seal closed any space around the holes where the drain lines exit the cabinet. Warm air must not be allowed to enter through any gaps or holes in the cabinet.

Electrical Connections

WARNING



Electric shock hazard! - Disconnect all power supplies before servicing.

Replace all parts and panels before operating.

Failure to do so can result in death or electrical shock.

WARNING

Run 24V Class II wiring only through specified low voltage opening. Run line voltage wiring only through specified high voltage opening. Do not combine voltage in one opening.

WARNING

Electric Shock Hazard.

Can cause injury or death.

Foil-faced insulation has conductive characteristics similar to metal. Be sure there are no electrical connections within 1/2" of the insulation. If the foil-faced insulation comes in contact with electrical voltage, the foil could provide a path for current to pass through to the outer metal cabinet. While the current produced may not be enough to trip existing electrical safety devices (e.g., fuses or circuit breakers), the current can be enough to cause an electrical shock hazard that could cause personal injury or death.



WARNING

Electric Shock Hazard. Can cause injury or death. Unit must be properly grounded in accordance with national and local codes.

Line voltage is present at all components when unit is not in operation on units with single-pole contactors. Disconnect all remote electric power supplies before opening access panel. Unit may have multiple power supplies.

- Wiring must conform to the current National Electric Code ANSI/NFPA No. 70, or Canadian Electric Code Part I, CSA Standard C22.1, and local building codes. Refer to following wiring diagrams. See unit nameplate for minimum circuit ampacity and maximum over-current protection size.

- Electrical wiring, disconnect means and over-current protection are to be supplied by the installer. Refer to the air handler rating plate for maximum over-current protection, minimum circuit ampacity, as well as operating voltage. Select the proper supply circuit conductors in accordance with tables 310-16 and 310-17 in the National Electric Code, ANSI/NFPA No. 70 or tables 1 through 4 in the Canadian Electric Code, Part I, CSA Standard C22.1.
- The power supply must be sized and protected according to the specifications supplied on the product.
- This air handler is factory-configured for 240 volt, single phase, 60 cycles. For 208-volt applications, see “208 Volt Conversion” later in this section.
- Separate openings have been provided for 24V low voltage and line voltage. Refer to the dimension illustration of specific location.
- This unit is provided with holes for conduit. Use provided caps to seal holes not used.
- Typical unit wiring (as well as wiring of optional field-installed electric heat) is given in Figure 14. Refer to the instructions provided with the electric heat section for proper installation.

NOTE: To avoid the possibility of moisture damage to the control in some right-hand discharge configurations, the control panel can be relocated to the end panel as shown in Figure 12.

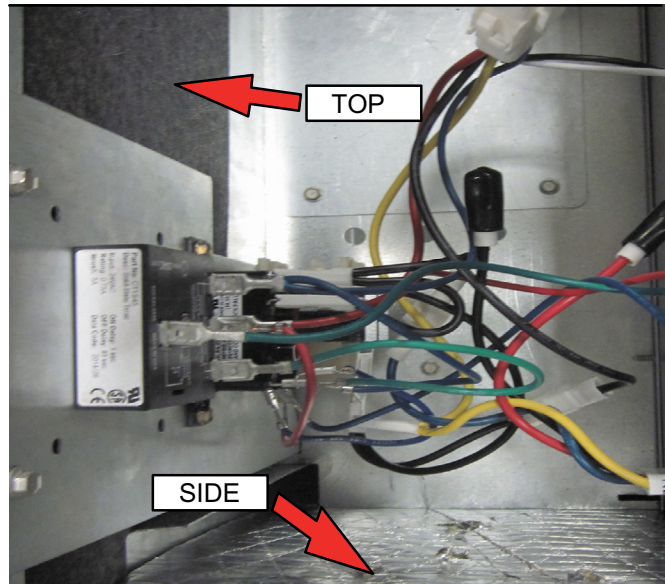

Figure 12. Control Panel Relocated to End Panel (Left-Hand Horizontal Configuration)

⚠ WARNING
USE COPPER CONDUCTORS ONLY

1. Disconnect all power supplies.
2. Remove the air handler access panel.
3. Route the field supply wires to the air handler electrical connection box.
4. Use UL-listed wire nuts to connect the field supply conductors to the unit black and yellow leads, and the ground wire to ground terminal marked GND.
5. Replace the air handler access panel.

208 Volt Conversion

1. Disconnect all power supplies.
2. Remove the air handler access panel.
3. Using the wiring diagram located on the unit access panel as a reference, move the 2 connected black transformer leads from the 240 volt terminal on the transformer to the 208 volt terminal on the transformer.

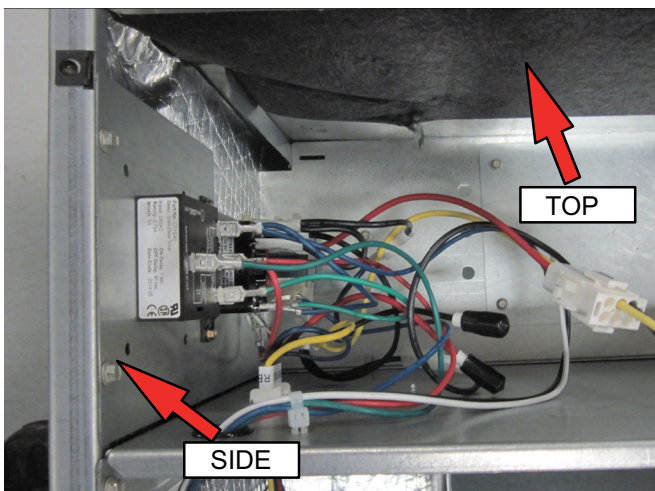

Figure 11. Electrical Connections (Upflow Configuration)

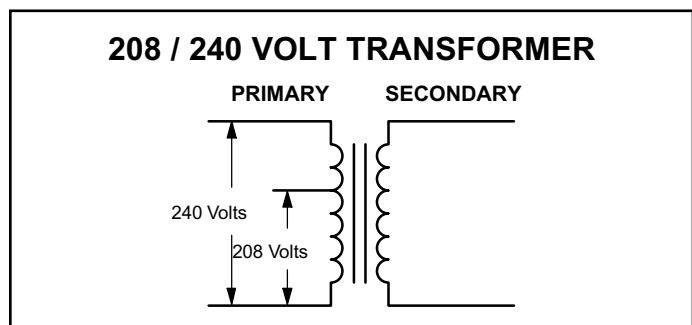



Figure 13. Converting Unit from 240VAC to 208VAC

0518



Form No. 537981-01

Supersedes

ELECTRIC HEAT

CONSTANT TORQUE LABEL WIRING DIAGRAM

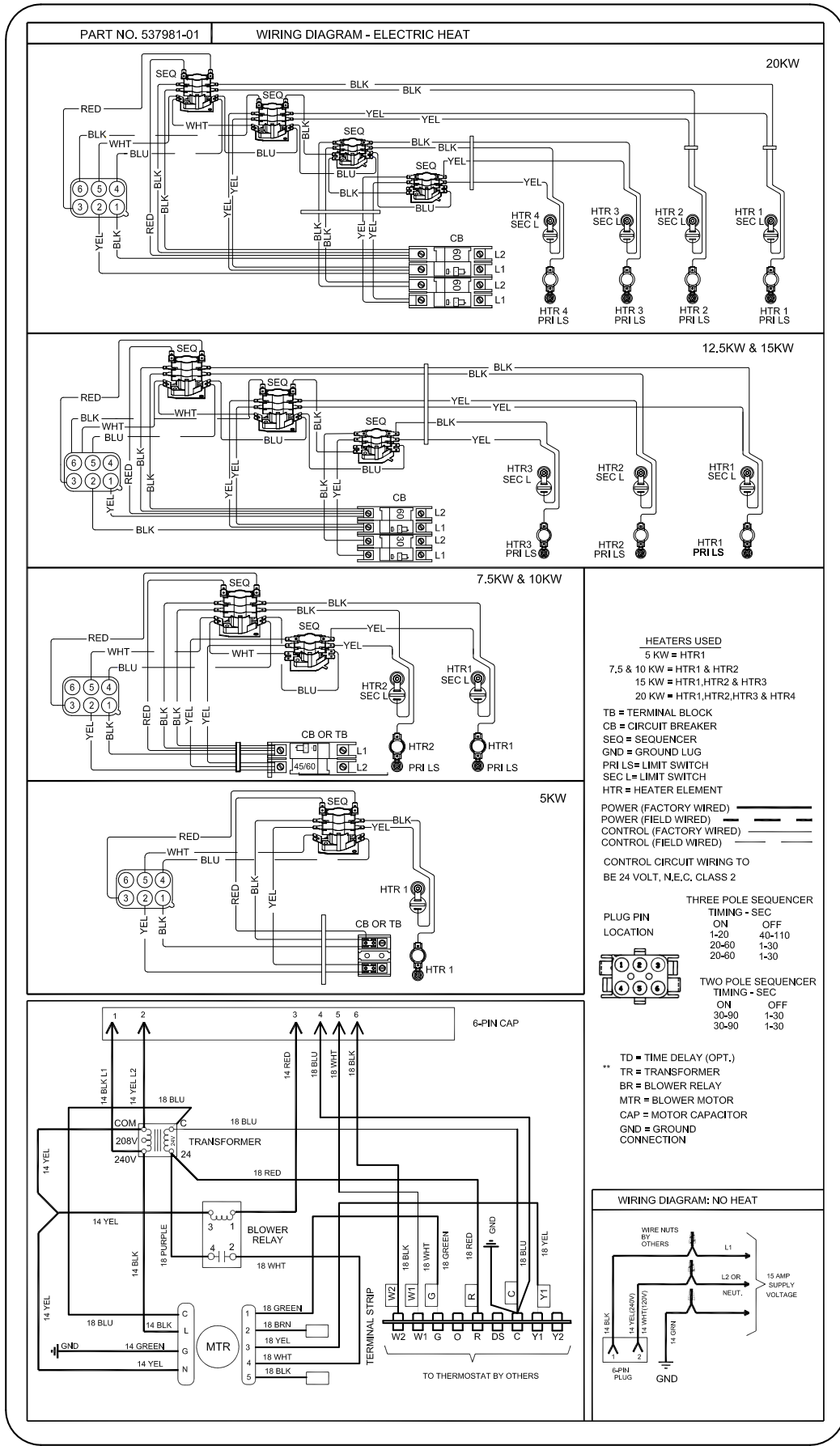

Figure 14. Typical Wiring Diagram MAHM*ETA Air Handler with Electric Heat – (Constant Torque Motor)

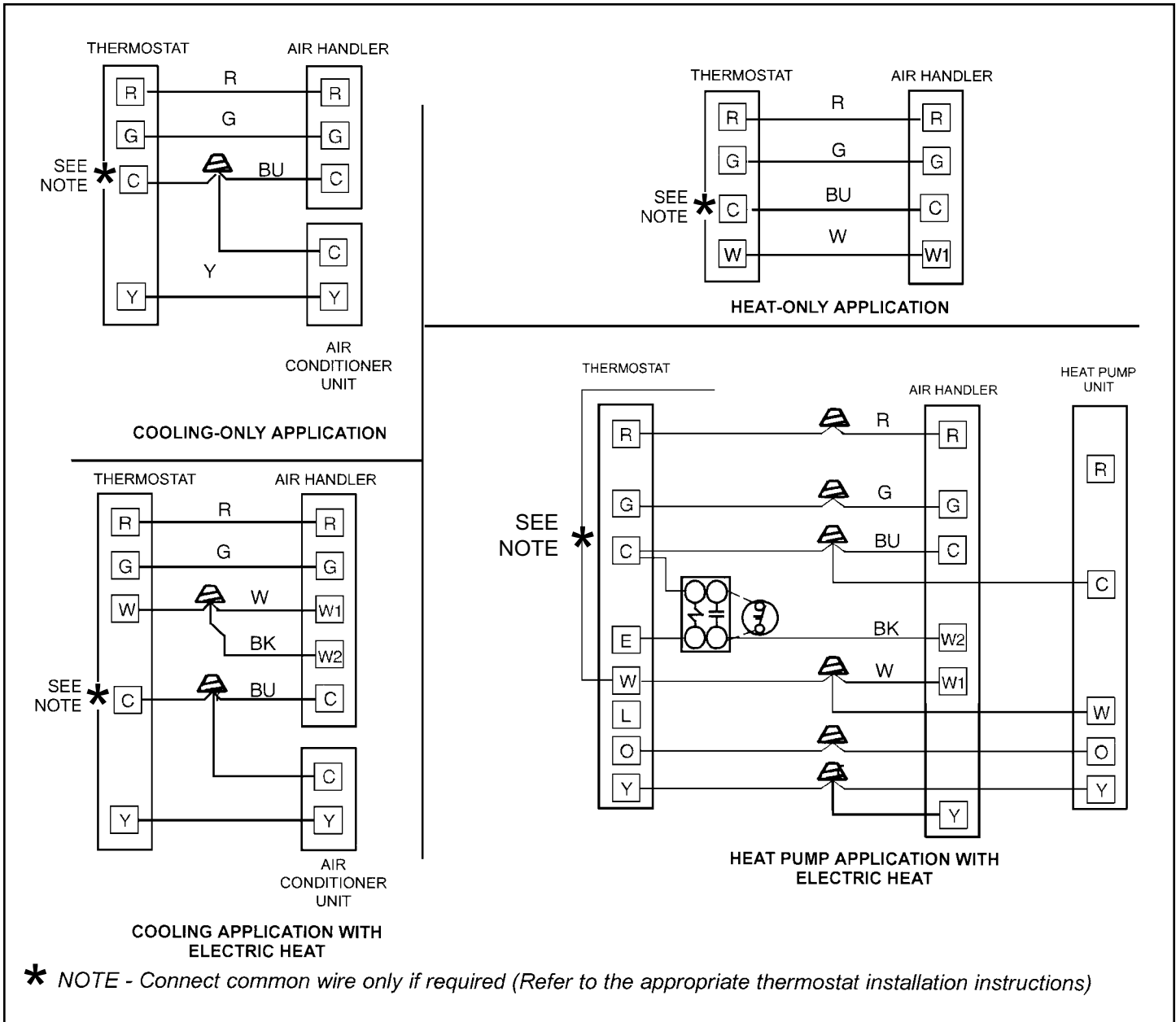

Figure 15. Low Voltage Connections (Constant Torque Motor)

Blower Performance Data

	Speed Tap	Application	External Static Pressure (in. w.c.)				
			0.1	0.2	0.3	0.4	0.5
-24	1	Fan Only	590	575	530	480	430
	2	Matched with 1.5 ton condensing unit	750	650	610	550	480
	3	Nominal 2 ton match without electric heat	950	825	785	740	690
	4	Nominal 2 ton match with electric heat	1040	1020	985	940	920
	5	High static application	1160	1140	1120	1080	1050
-30	1	Fan Only	700	665	625	565	490
	2	Matched with 2 ton condensing unit	860	810	770	715	665
	3	Nominal 2.5 ton match without electric heat	1040	1010	980	940	890
	4	Nominal 2.5 ton match with electric heat	1140	1100	1045	1015	980
	5	High static application	1390	1375	1340	1285	1245
-36	1	Fan Only	850	800	750	665	600
	2	Matched with 2.5 ton condensing unit	1080	950	910	850	775
	3	Nominal 3 ton match without electric heat	1270	1230	1170	1120	1060
	4	Nominal 3 ton match with electric heat	1440	1400	1330	1280	1240
	5	High static application	1540	1475	1430	1380	1300
-42	1	Fan Only	990	915	860	810	725
	2	Matched with 3 ton condensing unit	1190	1150	1100	1060	1020
	3	Nominal 3.5 ton match without electric heat	1390	1350	1315	1280	1230
	4	Nominal 3.5 ton match with electric heat	1665	1625	1585	1550	1510
	5	High static application	1750	1710	1675	1640	1600
-48	1	Fan Only	1255	1210	1155	1115	1050
	2	Matched with 3.5 ton condensing unit	1485	1450	1410	1365	1330
	3	Nominal 4 ton match without electric heat	1720	1675	1630	1595	1550
	4	Nominal 4 ton match with electric heat	1720	1675	1630	1595	1550
	5	High static application	1840	1795	1755	1720	1680
-60	1	Fan Only	1100	1050	1000	925	830
	2	Matched with 4 ton condensing unit	1625	1595	1565	1520	1490
	3	Nominal 5 ton match without electric heat	1815	1780	1760	1730	1685
	4	Nominal 5 ton match with electric heat	1900	1870	1835	1810	1765
	5	High static application	1980	1955	1920	1890	1860

Table 2. MAHM*ETA Constant Torque Air Handler Wet Air Flow Data

Air Flow - Cooling Blower Speed

The cooling blower speed is factory configured to provide correct air flow for an outdoor unit that matches the cooling capacity rating of the air handler (Tap 3).

If the outdoor unit is smaller than the maximum cooling capacity rating for the air handler, the cooling blower speed may need to be changed. Refer to blower performance chart (Table 2).

WARNING



ELECTRIC SHOCK HAZARD!

Disconnect all power supplies before servicing.

Replace all parts and panels before operating.

Failure to do so can result in death or electrical shock.

Adjusting Blower Speed

Motor Speed Taps

NOTE - Motor is programmed for a 45-second OFF delay on all speed taps except TAP #1 (continuous fan speed).

These settings are for nominal tonnage match-ups with the MAHM*ETA units. When matched with other sizes, it is recommended that the CFM be adjusted to approximately 400 CFM per ton.

Tap	Operation	Remarks
1	Continuous fan	Continuous fan speed is energized (24 volt input to G).
2	Lower tonnage speed	Air flow set at 1/2 ton lower than nominal capacity (e.g. if 3-ton air handler is used with 2.5-ton outdoor unit).
3	A/C or heat pump - no electric heat	Air flow set at 400 SCFM per ton at minimum static allowed.
4*	A/C or Heat pump with electric heat	Air flow set at 400 SCFM per ton at .5 static. Energized when electric heat element has a call for heat.
5	High static applications	Air flow set at 400 cfm per ton at .8 static. (Connect white wire from blower relay to Tap 5 instead of Tap 4)

* Tap 4 is minimum setting for electric heat

Table 3.

Operation Inspection

NOTE: Refer to outdoor unit installation instructions for system start-up instructions and refrigerant charging instructions.

Pre-Start-Up Checks

- Is the air handler properly and securely installed?
- If horizontally configured, is the unit sloped up to 5/8 inch toward drain lines?
- Will the unit be accessible for servicing?
- Has an auxiliary pan been provided under the unit with separate drain for units installed above a finished ceiling or in any installation where condensate overflow could cause damage?
- Have ALL unused drain pan ports been properly plugged?
- Has the condensate line been properly sized, run, trapped, pitched, and tested?
- Is the duct system correctly sized, run, sealed, and insulated?
- Have all cabinet openings and wiring been sealed?
- Is the indoor coil factory-installed TXV properly sized for the outdoor unit being used?
- Have all unused parts and packaging been disposed of?
- Is the filter clean, in place, and of adequate size?
- Is the wiring neat, correct, and in accordance with the wiring diagram?
- Is the unit properly grounded and protected (fused)?
- Is the thermostat correctly wired and in a good location?
- Are all access panels in place and secure?

Check Blower Operation

1. Set thermostat to FAN ON.
2. The indoor blower should turn on.

Check Unit Operation

1. Set thermostat to force a call for cooling (approximately 5°F lower than the indoor ambient temperature).
2. The outdoor unit should turn on immediately.
3. Check the air flow from a register to confirm that the system is moving cooled air.
4. Set the thermostat 5°F higher than the indoor temperature. The indoor blower and outdoor unit should cycle off. Air handler should cycle off 45 seconds after the outdoor unit shuts off.

Check Electric Heat (If Used)

1. Set thermostat to call for auxiliary heat (approximately 5°F above ambient temperature). The indoor blower and auxiliary heat should come on together. Allow a minimum of 3 minutes for all sequencers to cycle on.
2. Set the thermostat so that it does not call for heat. Allow up to 5 minutes for all sequencers to cycle off.

Operation

Cooling (Cooling Only or Heat Pump)

When the thermostat calls for cooling, 24 volts is put on the blower time-delay relay coil and then the indoor blower relay energizes. The normally open contacts close, causing the indoor blower motor to operate. The circuit between **R** and **Y** is completed, closing the circuit to the contactor in the outdoor unit, starting the compressor and outdoor fan motor.

On heat pumps, circuit **R** and **O** energizes the reversing valve, switching the valve to the cooling position. (The reversing valve remains energized as long as the thermostat selector switch is in the **COOL** position.)

At the completion of the cooling demand, the indoor blower and outdoor unit should cycle off. Air handler should cycle off 45 seconds after the outdoor unit shuts off.

Heating (Electric Heat Only)

When the thermostat calls for heat, the circuit between **R** and **W** is completed, and the heat sequencer is energized. A time delay follows before the heating elements and the indoor blower motor come on. Units with a second heat sequencer can be connected with the first sequencer to **W** on the thermostat sub-base, or they may also be connected to a second stage on the sub-base.

Heating (Heat Pump)

When the thermostat calls for heating, 24 volts is applied to the blower time-delay relay coil. The normally open contacts close, causing the indoor blower motor to operate. The circuit between **R** and **Y** is completed, closing the circuit to the contactor in the outdoor unit, starting the compressor and outdoor fan motor.

If the room temperature continues to decrease, the circuit between **R** and **W1** is completed by the second-stage heat room thermostat. Circuit **R-W1** energizes a heat sequencer. The completed circuit will energize supplemental electric heat (if applicable). Units with a second heat sequencer can be connected with the first sequencer to **W1** on the thermostat. They may also be connected to a second heating stage **W2** on the thermostat sub-base.

Emergency Heat (Heating Heat Pump)

If the selector switch on the thermostat is set to the emergency heat position, the heat pump will be locked out of the heating circuit, and all heating will be electric heat (if applicable). A jumper should be placed between **W2** and **E** on the thermostat sub-base so that the electric heat control will transfer to the first-stage heat on the thermostat. This will allow the indoor blower to cycle on and off with the electric heat when the fan switch is in the **AUTO** position.

Maintenance

IMPORTANT

Do not operate system without a filter. A filter is required to protect the coil, blower, and internal parts from excessive dirt and dust. The MAHM*ETA units are shipped with filters. Remove this filter if the return air register already has a filter.

- Inspect air filters at least once a month and replace or clean as required. Dirty filters are the most common cause of inadequate heating or cooling performance.
- Replace disposable filters. Cleanable filters can be cleaned by soaking in mild detergent and rinsing with cold water.
- Install new/clean filters with the arrows on the side pointing in the direction of air flow. Do not replace a cleanable (high velocity) filter with a disposable (low velocity) filter unless return air system is properly sized for it.
- If water should start coming from the secondary drain line, a problem exists which should be investigated and corrected. Contact a qualified service technician.

Professional Maintenance

NOTICE

Failure to follow instructions will cause damage to the unit.

This unit is equipped with an aluminum coil. Aluminum coils may be damaged by exposure to solutions with a pH below 5 or above 9. The aluminum coil should be cleaned using potable water at a moderate pressure (less than 50psi). If the coil cannot be cleaned using water alone, it is recommended to use a coil cleaner with a pH in the range of 5 to 9. The coil must be rinsed thoroughly after cleaning.

In coastal areas, the coil should be cleaned with potable water several times per year to avoid corrosive buildup (salt).

Cabinet Insulation

▲ IMPORTANT

DAMAGED INSULATION MUST BE REPAIRED OR REPLACED before the unit is put back into operation. Insulation loses its insulating value when wet, damaged, separated or torn.

Matte- or foil-faced insulation is installed in indoor equipment to provide a barrier between outside air conditions (surrounding ambient temperature and humidity) and the varying conditions inside the unit. If the insulation barrier is damaged (wet, ripped, torn or separated from the cabinet walls), the surrounding ambient air will affect the inside surface temperature of the cabinet.

The temperature/humidity difference between the inside and outside of the cabinet can cause condensation on the inside or outside of the cabinet which leads to sheet metal corrosion and, subsequently, component failure.

Repairing Damaged Insulation

Areas of condensation on the cabinet surface are an indication that the insulation is in need of repair.

If the insulation in need of repair is otherwise in good condition, the insulation should be cut in an X pattern, peeled open, glued with an appropriate all-purpose glue and placed back against the cabinet surface, being careful to not overly compress the insulation so the insulation can retain its original thickness. If such repair is not possible, replace the insulation. If using foil-faced insulation, any cut, tear, or separations in the insulation surface must be taped with a similar foil-faced tape.

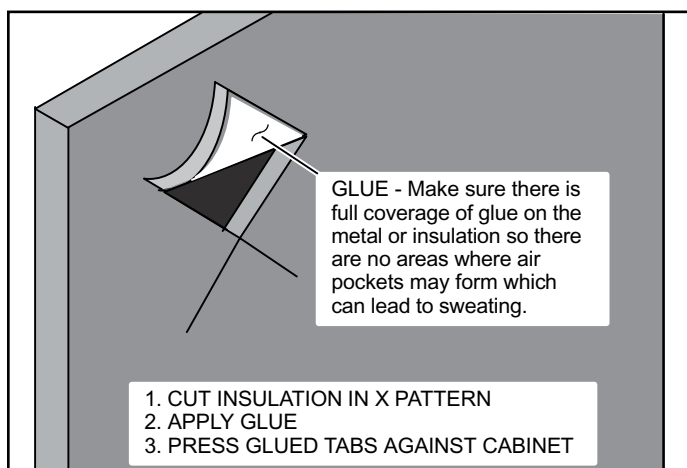

Figure 16. Recommended Blower Speed Taps

Use of Air Handler During Construction

It is not recommended to use this air handler unit during any phase of construction. Very low return air temperatures, harmful vapors and operation of the unit with clogged or misplaced filters will damage the unit.

Air handler units may be used for heating (heat pumps) or cooling of buildings under construction, if the following conditions are met:

- A room thermostat must control the air handler. The use of fixed jumpers is not allowed.
- Air filter must be installed in the system and must be maintained during construction.
- Air filter must be replaced upon construction completion.
- The air handler evaporator coil, supply fan assembly and duct system must be thoroughly cleaned following final construction clean-up.
- All air handler operating conditions must be verified according to these installation instructions.

Installing Contractor's Name _____
 Installing Contractor's Phone _____
 Job Address _____

Installing Date _____
 Air Handler Model # _____

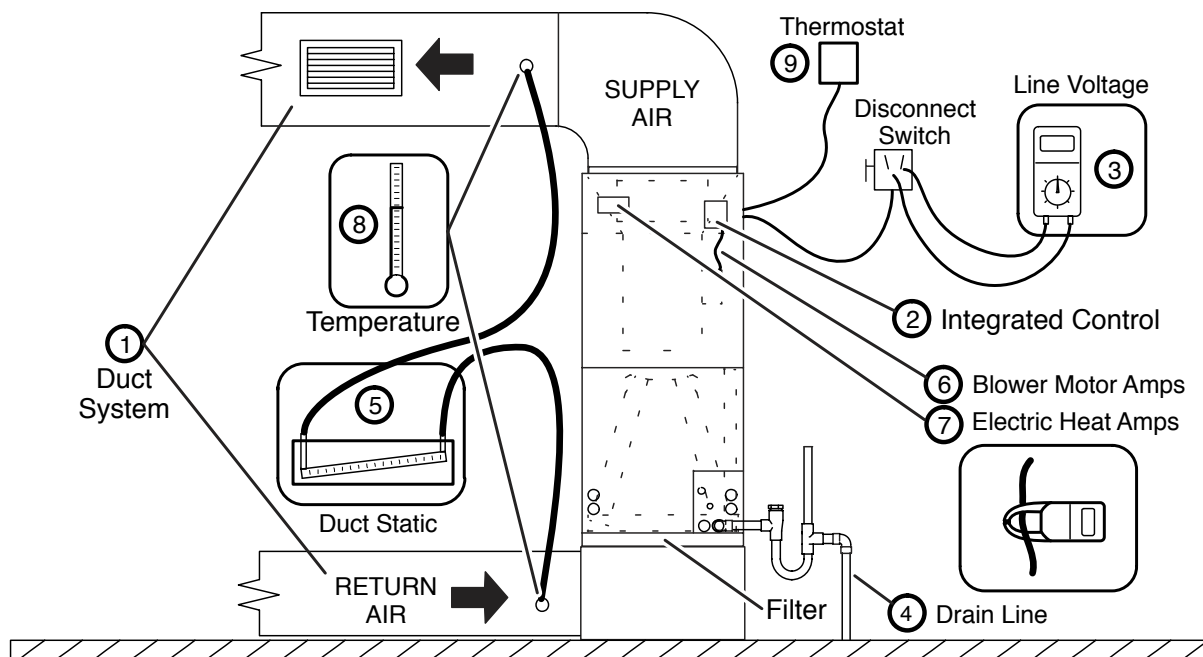

- | | |
|--|---|
| <p>① DUCT SYSTEM</p> <p>SUPPLY AIR DUCT</p> <p><input type="checkbox"/> Sealed</p> <p><input type="checkbox"/> Insulated (if necessary)</p> <p><input type="checkbox"/> Registers Open and Unobstructed</p> <p>RETURN AIR DUCT</p> <p><input type="checkbox"/> Sealed</p> <p><input type="checkbox"/> Filter Installed and Clean</p> <p><input type="checkbox"/> Registers Open and Unobstructed</p> <p>② INTEGRATED CONTROL</p> <p><input type="checkbox"/> Jumpers Configured Correctly (if applicable)</p> <p><input type="checkbox"/> Appropriate Links in Place (if applicable)</p> <p>③ VOLTAGE CHECK</p> <p><input type="checkbox"/> Supply Voltage _____</p> <p><input type="checkbox"/> Low Voltage _____</p> <p><input type="checkbox"/> Electrical Connections Tight</p> <p>④ DRAIN LINE</p> <p><input type="checkbox"/> Leak Free</p> <p><input type="checkbox"/> Explained Operation of System to Homeowner</p> | <p>⑤ TOTAL EXTERNAL STATIC (dry coil)</p> <p style="text-align: right;">dry coil wet coil</p> <p>Supply External Static _____</p> <p>Return External Static _____</p> <p>Total External Static = _____</p> <p>⑥ ELECTRIC HEAT AMPS _____</p> <p>⑦ INDOOR BLOWER AMPS _____</p> <p>INDOOR BLOWER CFM _____</p> <p>⑧ TEMPERATURE DROP (Cooling Mode)</p> <p>Return Duct Temperature _____</p> <p>Supply Duct Temperature – _____</p> <p>Temperature Drop = _____</p> <p>⑧ TEMPERATURE RISE (Heating Mode)</p> <p>Return Duct Temperature _____</p> <p>Supply Duct Temperature – _____</p> <p>Temperature Rise = _____</p> <p>⑨ THERMOSTAT</p> <p><input type="checkbox"/> Adjusted and Programmed</p> <p><input type="checkbox"/> Operation Explained to Owner</p> |
|--|---|

Technician's Name: _____ Date Start-Up & Performance Check Completed _____

Figure 17. Start-up and Performance Checklist (Upflow Configuration)

Installing Contractor's Name _____ Installing Date _____
 Installing Contractor's Phone _____ Air Handler Model # _____
 Job Address _____

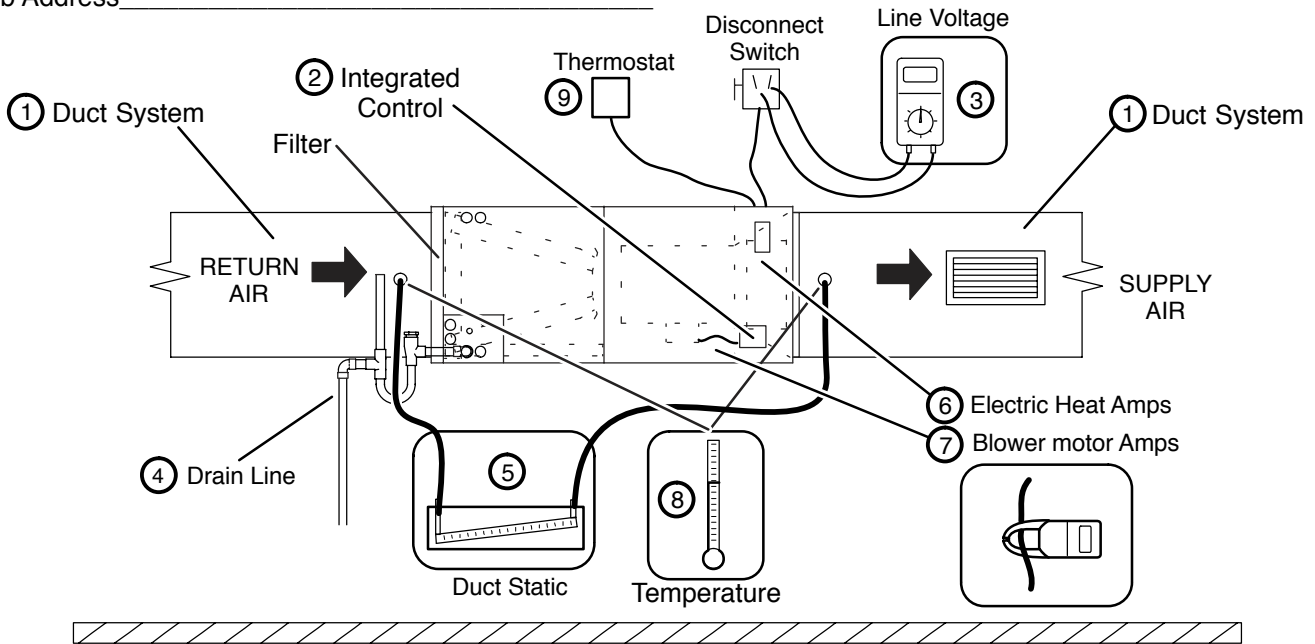

- | | |
|--|---|
| <p>① DUCT SYSTEM</p> <p>SUPPLY AIR DUCT</p> <p><input type="checkbox"/> Sealed</p> <p><input type="checkbox"/> Insulated (if necessary)</p> <p><input type="checkbox"/> Registers Open and Unobstructed</p> <p>RETURN AIR DUCT</p> <p><input type="checkbox"/> Sealed</p> <p><input type="checkbox"/> Filter Installed and Clean</p> <p><input type="checkbox"/> Registers Open and Unobstructed</p> <p>② INTEGRATED CONTROL</p> <p><input type="checkbox"/> Jumpers Configured Correctly (if applicable)</p> <p><input type="checkbox"/> Appropriate Links in Place (if applicable)</p> <p>③ VOLTAGE CHECK</p> <p><input type="checkbox"/> Supply Voltage _____</p> <p><input type="checkbox"/> Low Voltage _____</p> <p><input type="checkbox"/> Electrical Connections Tight</p> <p>④ DRAIN LINE</p> <p><input type="checkbox"/> Leak Free</p> <p><input type="checkbox"/> Explained Operation of System to Homeowner</p> | <p>⑤ TOTAL EXTERNAL STATIC (dry coil)</p> <p style="text-align: right;">dry coil wet coil</p> <p>Supply External Static _____</p> <p>Return External Static _____</p> <p>Total External Static = _____</p> <p>⑥ ELECTRIC HEAT AMPS _____</p> <p>⑦ INDOOR BLOWER AMPS _____</p> <p>INDOOR BLOWER CFM _____</p> <p>⑧ TEMPERATURE DROP (Cooling Mode)</p> <p>Return Duct Temperature _____</p> <p>Supply Duct Temperature – _____</p> <p>Temperature Drop = _____</p> <p>⑧ TEMPERATURE RISE (Heating Mode)</p> <p>Return Duct Temperature _____</p> <p>Supply Duct Temperature – _____</p> <p>Temperature Rise = _____</p> <p>⑨ THERMOSTAT</p> <p><input type="checkbox"/> Adjusted and Programmed</p> <p><input type="checkbox"/> Operation Explained to Owner</p> |
|--|---|

Technician's Name: _____ Date Start-Up & Performance Check Completed _____

Figure 18. Start-up and Performance Checklist (Horizontal Configuration)



MRCOOL®

COMFORT MADE SIMPLE

Signature Series

MAHM*ETA Air Handler

ELECTRICIAN and/or HVAC TECHNICIAN:

LICENSE #:

INSTALLATION DATE:

INSTALLATION LOCATION:

SERIAL NUMBER:

The design and specifications of this product and/or manual are subject to change without prior notice. Consult with the sales agency or manufacturer for details.

MAHM*TA

PRODUCT SPECIFICATIONS

ENHANCED AIR HANDLER



APPLICATION

- 2 - 5 ton systems
- Sequenced for demand management
- External access to heater circuit breakers

INSTALLATION

- One piece design
- Smaller profile for closet applications
- Multi-position = Upflow/ Horizontal Left/ Horizontal Right/ Counter Flow (with kit)
- Approved for installation in manufactured housing and mobile homes

CABINET

- Foil faced insulation for enhanced indoor air quality
- Double hemmed technology for increased structural rigidity
- Improved gasketing on doors to reduce air leakage
- Filter rack with thumb screws for easy access and removal
- Polymer plugs on drain locations for easy installation
- Baked polyester paint finished over galvanized steel for maximum durability
- High strength/heat resistant/corrosion resistance SMC drain pans
- Antimicrobial treated drain pan to resist mold and mildew growth
- Meets 2 % or less air leakage

COILS

- Coolguard™ total corrosion protection technology designed coil
- Enhanced tube-and-fin coil design featuring MHT™ Technology
- Lanced fins for maximum heat transfer
- Factory tested for leakproof construction

COMPONENTS

- Efficient Constant Torque blower motors
- Standard transformer and blower relay
- Field installed 2.5, 5, 7.5, 10, 12.5, 15, and 20 kW electric heat kits with ease of assembly quick wire connectors
- Built-in indoor time delay for increased efficiency and comfort

WARRANTY

10-year limited warranty on all parts, extended warranty available.



MODEL NUMBER GUIDE

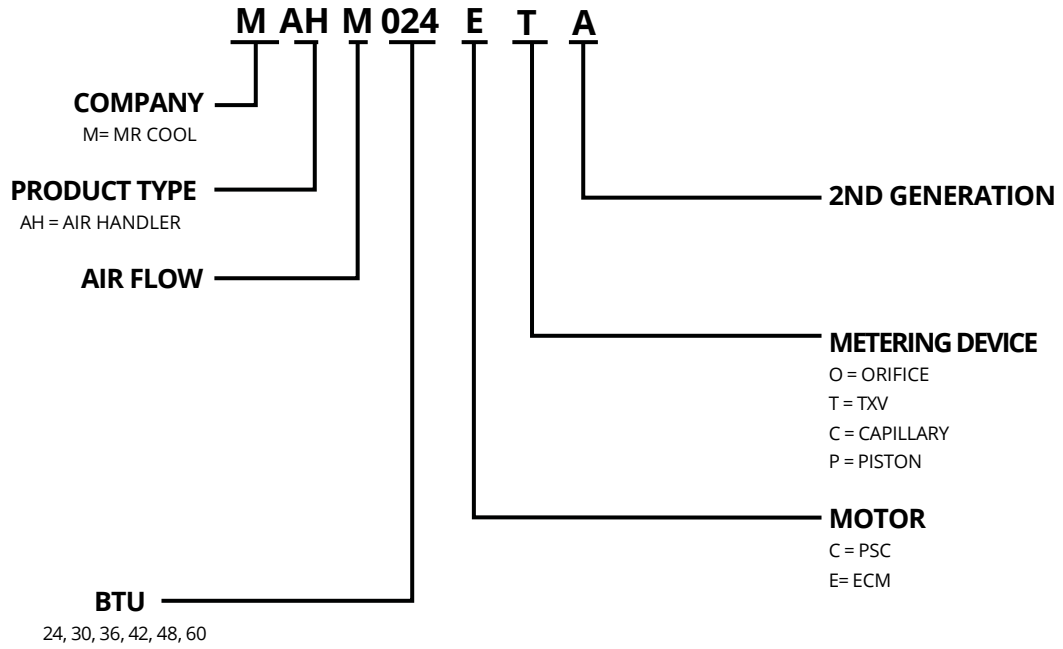

PHYSICAL

Model	Volts/Hz/Phase	Max. Elec. Heat (kW)	Transformer Size & Type	Filter Size (inches)	Refrigerant Connection		Installed TXV Size	Weight (lbs.)
					Suction (in.)	Liquid (in.)		
MAHM024ETA	208-230/60/1	10	40 VA Class 2	15 x 20	3/4	3/8	H4TXV01	127
MAHM030ETA	208-230/60/1	15	40 VA Class 2	15 x 20	3/4	3/8	H4TXV01	133
MAHM036ETA	208-230/60/1	15	40 VA Class 2	18 x 20	7/8	3/8	H4TXV02	163
MAHM042ETA	208-230/60/1	15	40 VA Class 2	18 x 20	7/8	3/8	H4TXV02	168
MAHM048ETA	208-230/60/1	20	40 VA Class 2	18 x 20	7/8	3/8	H4TXV02	186
MAHM060ETA	208-230/60/1	20	40 VA Class 2	18 x 20	7/8	3/8	H4TXV03	186

ACCESSORIES

DESCRIPTION	WHERE USED	KIT NUMBER
Down-flow Kit	24, 30	MSHDK1830
	36, 42, 48, 60	MSHDK3660

ELECTRIC HEAT

Electric Heat Kits with Circuit Breaker			
5 kW	MHK05H	30A	18, 24, 30, 36, 42, 48, 60
7.5 kW	MHK07H	45A	18, 24, 30, 36, 42, 48, 60
10 kW	MHK10H	60A	24, 30, 36, 42, 48, 60
15 kW	MHK15H	60A + 25A	30, 36, 42, 48, 60
20 kW	MHK20H	60A + 50A	48, 60

* Circuit breaker must match rated "Max C/B Size"; replace breaker as necessary.

ELECTRICAL

Model	Heating Capacity (240V)			Blower Amps	Min. Circuit Ampacity				Max. Circuit Breaker Size				Single Point Power Supply					
	Nominal Heater Size kW	kW	Btuh		208V		240V		208V		240V		208V		240V			
					1	2	1	2	1	2	1	2	Amps	Fuse	Amps	Fuse		
MAHM24ETA	0	0	0	4.1	5.1		5.1		15		15							
	5	4.8	16400		27		30		30		30							
	7.5	7.5	25600		39		44		40		45							
	10	9.6	32700		48		55		50		60							
MAHM30ETA	0	0	0	4.1	5.1		5.1		15		15							
	5	4.8	16400		27		30		30		30							
	7.5	7.5	25600		39		44		40		45							
	10	9.6	32700		48		55		50		60							
	12.5	12.5	42600		43	19	48	22	45	20	50	25	62	70	70	70	70	
	15	14.4	49100		48	22	55	25	50	25	60	25	70	70	80	80	80	80
MAHM36ETA	0	0	0	4.1	5.1		5.1		15		15							
	5	4.8	16400		27		30		30		30							
	7.5	7.5	25600		39		44		40		45							
	10	9.6	32700		48		55		50		60							
	12.5	12.5	42600		43	19	48	22	45	20	50	25	62	70	70	70	70	
	15	14.4	49100		48	22	55	25	50	25	60	25	70	70	80	80	80	80
MAHM42ETA	0	0	0	6.0	7.5		7.5		15		15							
	5	4.8	16400		29		33		30		35							
	7.5	7.5	25600		41		47		45		50							
	10	9.6	32700		51		58		60		60							
	12.5	12.5	42600		45	19	51	22	45	20	60	25	64	70	73	80	80	
	15	14.4	49100		51	22	58	25	60	25	60	25	73	80	83	90	90	
MAHM48ETA	0	0	0	7.6	9.5		9.5		15		15							
	5	4.8	16400		31		35		35		35							
	7.5	7.5	25600		43		49		45		50							
	10	9.6	32700		53		60		60		60							
	12.5	12.5	42600		47	19	53	22	50	20	60	25	66	70	75	80	80	
	15	14.4	49100		53	22	60	25	60	25	60	25	75	80	85	90	90	
	20	19.2	65500		53	43	60	50	60	45	60	50	96	100	110	110	110	
MAHM60ETA	0	0	0	7.6	9.5		9.5		15		15							
	5	4.8	16400		31		35		35		35							
	7.5	7.5	25600		43		49		45		50							
	10	9.6	32700		53		60		60		60							
	12.5	12.5	42600		47	19	53	22	50	20	60	25	66	70	75	80	80	
	15	14.4	49100		53	22	60	25	60	25	60	25	75	80	85	90	90	
	20	19.2	65500		53	43	60	50	60	45	60	50	96	100	110	110	110	

1. For 208 volt use .751 correction factor for kW and Btuh
2. 12.5kW, 15 and 20kW (2 stage models) require 2 supply circuits
3. Circuit #1 includes blower motor amps except 20kW models

BLOWER

Model	Motor Size (hp)	Blower Size (in.)	Speed Tap	Application	CFM @ ESP - in. W.C.				
					0.1	0.2	0.3	0.4	0.5
MAHM24ETA	1/2	10 x 8	1	Fan Only	590	575	530	480	430
			2	Matched with 1.5 ton condensing unit	750	650	610	550	480
			3	Nominal 2 ton match without electric heat	950	825	785	740	690
			4	Nominal 2 ton match with electric heat	1040	1020	985	940	920
			5	High static application	1160	1140	1120	1080	1050
MAHM30ETA	1/2	10 x 8	1	Fan Only	700	665	625	565	490
			2	Matched with 2 ton condensing unit	860	810	770	715	665
			3	Nominal 2.5 ton match without electric heat	1040	1010	980	940	890
			4	Nominal 2.5 ton match with electric heat	1140	1100	1045	1015	980
			5	High static application	1390	1375	1340	1285	1245
MAHM36ETA	1/2	10 x 8	1	Fan Only	850	800	750	665	600
			2	Matched with 2.5 ton condensing unit	1080	950	910	850	775
			3	Nominal 3 ton match without electric heat	1270	1230	1170	1120	1060
			4	Nominal 3 ton match with electric heat	1440	1400	1330	1280	1240
			5	High static application	1540	1475	1430	1380	1300
MAHM42ETA	3/4	12 x 10	1	Fan Only	990	915	860	810	725
			2	Matched with 3 ton condensing unit	1190	1150	1100	1060	1020
			3	Nominal 3.5 ton match without electric heat	1390	1350	1315	1280	1230
			4	Nominal 3.5 ton match with electric heat	1665	1625	1585	1550	1510
			5	High static application	1750	1710	1675	1640	1600
MAHM48ETA	1	12 x 10	1	Fan Only	1250	1210	1185	1130	1110
			2	Matched with 3.5 ton condensing unit	1500	1465	1435	1400	1360
			3	Nominal 4 ton match without electric heat	1715	1670	1635	1615	1575
			4	Nominal 4 ton match with electric heat	1770	1735	1700	1670	1650
			5	High static application	1895	1860	1835	1795	1760
MAHM60ETA	1	12 x 10	1	Fan Only	1100	1050	1000	925	830
			2	Matched with 4 ton condensing unit	1625	1595	1565	1520	1490
			3	Nominal 5 ton match without electric heat	1815	1785	1760	1730	1685
			4	Nominal 5 ton match with electric heat	1905	1870	1835	1810	1765
			5	High static application	1980	1955	1925	1895	1860

All data given while air handler is operating with a wet coil and without air filter installed.
 Speed tap 1 to be used for continuous fan operation.
 Speed tap 2 to be used for cooling speed of 1/2 ton smaller outdoor unit match. Speed tap 3 to be used for cooling speed of nominal tonnage match.
 Speed tap 4 to be used for heating speed for units with electric heat. This is the minimum speed for heating. Speed tap 5 to be used for high static applications.

DIMENSIONS (IN.)

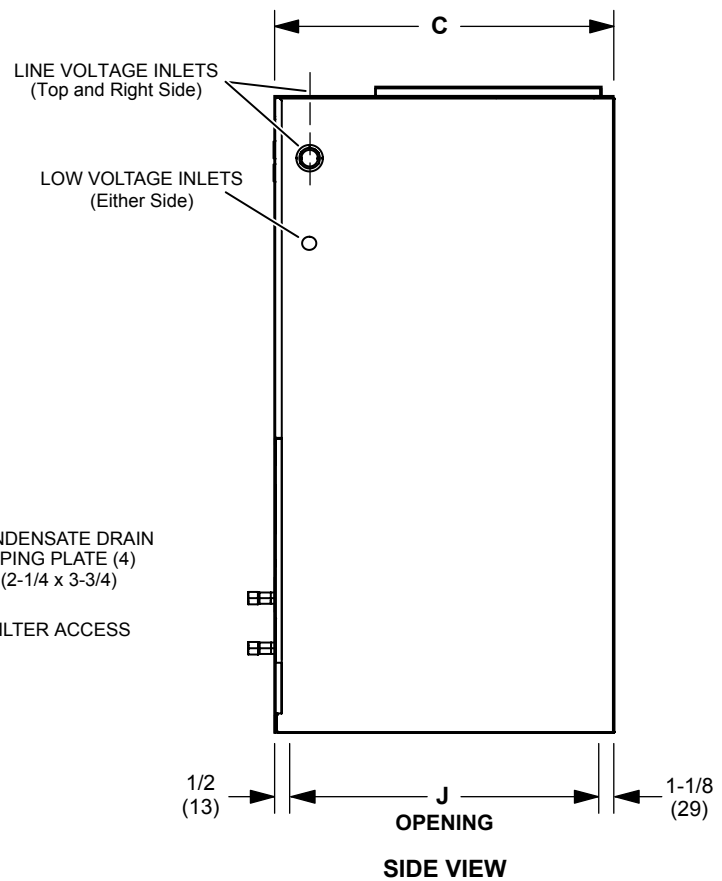
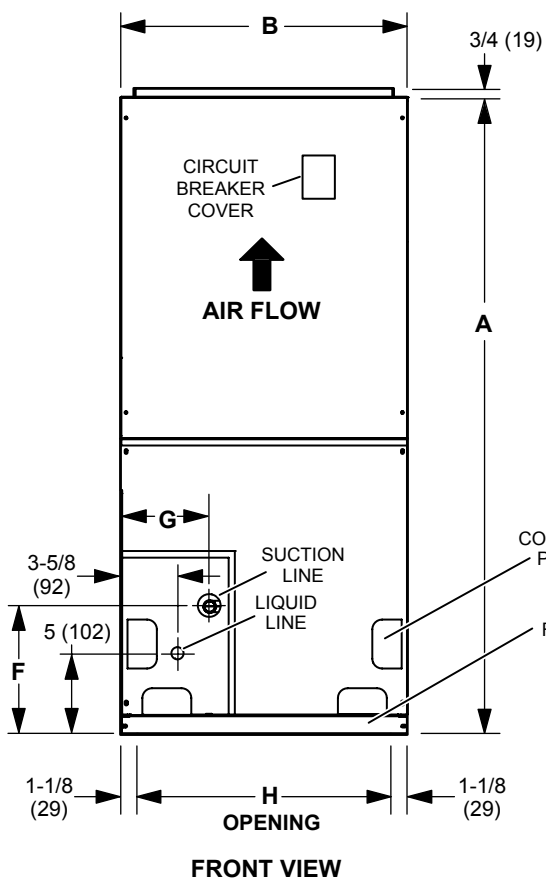
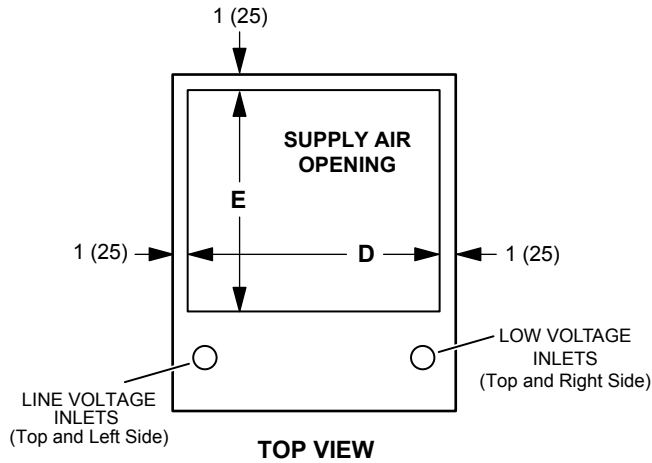

Dimension	18		24		30		36-42		48		60	
	in.	mm	in.	mm	in.	mm	in.	mm	in.	mm	in.	mm
A	43.5	1105	45.5	1156	47	1194	53.63	1362	55	1397	59.75	1518
B	18.5	470	18.5	470	18.5	470	21.5	546	21.5	546	21.5	546
C	16.5	419	16.5	419	16.5	419	19.5	495	19.5	495	19.5	495
D	16.25	413	16.25	413	16.25	413	19.25	489	19.25	489	19.25	489

All specifications and illustrations subject to change without notice and without incurring obligations.