

Certificate of Product Ratings

AHRI Certified Reference Number : 207177528

Date : 07-22-2021

Model Status : Active

AHRI Type : RCU-A-CB (Split System: Air-Cooled Condensing Unit, Coil with Blower)

Outdoor Unit Brand Name : MRCOOL

Outdoor Unit Model Number (Condenser or Single Package) : MDUCO18024036

Indoor Unit Model Number (Evaporator and/or Air Handler) : MDUI18024E

Region : All (AK, AL, AR, AZ, CA, CO, CT, DC, DE, FL, GA, HI, ID, IL, IA, IN, KS, KY, LA, MA, MD, ME, MI, MN, MO, MS, MT, NC, ND, NE, NH, NJ, NM, NV, NY, OH, OK, OR, PA, RI, SC, SD, TN, TX, UT, VA, VT, WA, WV, WI, WY, U.S. Territories)

Region Note : Central air conditioners manufactured prior to January 1, 2015 are eligible to be installed in all regions until June 30, 2016. Beginning July 1, 2016 central air conditioners can only be installed in region(s) for which they meet the regional efficiency requirement.

The manufacturer of this MRCOOL product is responsible for the rating of this system combination.

Rated as follows in accordance with the latest edition of AHRI 210/240 with Addendum 1, Performance Rating of Unitary Air-Conditioning & Air-Source Heat Pump Equipment and subject to rating accuracy by AHRI-sponsored, independent, third party testing:

Cooling Capacity (A2) - Single or High Stage (95F), btuh : 24000

SEER : 20.00

EER (A2) - Single or High Stage (95F) : 12.50

AHRI CERTIFIED®
www.ahridirectory.org

†"Active" Model Status are those that an AHRI Certification Program Participant is currently producing AND selling or offering for sale; OR new models that are being marketed but are not yet being produced."Production Stopped" Model Status are those that an AHRI Certification Program Participant is no longer producing BUT is still selling or offering for sale.
Ratings that are accompanied by WAS indicate an involuntary re-rate. The new published rating is shown along with the previous (i.e. WAS) rating.

DISCLAIMER

AHRI does not endorse the product(s) listed on this Certificate and makes no representations, warranties or guarantees as to, and assumes no responsibility for, the product(s) listed on this Certificate. AHRI expressly disclaims all liability for damages of any kind arising out of the use or performance of the product(s), or the unauthorized alteration of data listed on this Certificate. Certified ratings are valid only for models and configurations listed in the directory at www.ahridirectory.org.

TERMS AND CONDITIONS

This Certificate and its contents are proprietary products of AHRI. This Certificate shall only be used for individual, personal and confidential reference purposes. The contents of this Certificate may not, in whole or in part, be reproduced; copied; disseminated; entered into a computer database; or otherwise utilized, in any form or manner or by any means, except for the user's individual, personal and confidential reference.

CERTIFICATE VERIFICATION

The information for the model cited on this certificate can be verified at www.ahridirectory.org, click on "Verify Certificate" link and enter the AHRI Certified Reference Number and the date on which the certificate was issued, which is listed above, and the Certificate No., which is listed at bottom right.

©2021 Air-Conditioning, Heating, and Refrigeration Institute



we make life better™

CERTIFICATE NO.:

132714461345742143

Certificate of Product Ratings

AHRI Certified Reference Number : 207177529

Date : 07-22-2021

Model Status : Active

AHRI Type : RCU-A-CB (Split System: Air-Cooled Condensing Unit, Coil with Blower)

Outdoor Unit Brand Name : MRCOOL

Outdoor Unit Model Number (Condenser or Single Package) : MDUCO18024036

Indoor Unit Model Number (Evaporator and/or Air Handler) : MDUI18036E

Region : All (AK, AL, AR, AZ, CA, CO, CT, DC, DE, FL, GA, HI, ID, IL, IA, IN, KS, KY, LA, MA, MD, ME, MI, MN, MO, MS, MT, NC, ND, NE, NH, NJ, NM, NV, NY, OH, OK, OR, PA, RI, SC, SD, TN, TX, UT, VA, VT, WA, WV, WI, WY, U.S. Territories)

Region Note : Central air conditioners manufactured prior to January 1, 2015 are eligible to be installed in all regions until June 30, 2016. Beginning July 1, 2016 central air conditioners can only be installed in region(s) for which they meet the regional efficiency requirement.

The manufacturer of this MRCOOL product is responsible for the rating of this system combination.

Rated as follows in accordance with the latest edition of AHRI 210/240 with Addendum 1, Performance Rating of Unitary Air-Conditioning & Air-Source Heat Pump Equipment and subject to rating accuracy by AHRI-sponsored, independent, third party testing:

Cooling Capacity (A2) - Single or High Stage (95F), btuh : 36000

SEER : 18.00

EER (A2) - Single or High Stage (95F) : 12.20

AHRI CERTIFIED®
www.ahridirectory.org

†"Active" Model Status are those that an AHRI Certification Program Participant is currently producing AND selling or offering for sale; OR new models that are being marketed but are not yet being produced."Production Stopped" Model Status are those that an AHRI Certification Program Participant is no longer producing BUT is still selling or offering for sale.
Ratings that are accompanied by WAS indicate an involuntary re-rate. The new published rating is shown along with the previous (i.e. WAS) rating.

DISCLAIMER

AHRI does not endorse the product(s) listed on this Certificate and makes no representations, warranties or guarantees as to, and assumes no responsibility for, the product(s) listed on this Certificate. AHRI expressly disclaims all liability for damages of any kind arising out of the use or performance of the product(s), or the unauthorized alteration of data listed on this Certificate. Certified ratings are valid only for models and configurations listed in the directory at www.ahridirectory.org.

TERMS AND CONDITIONS

This Certificate and its contents are proprietary products of AHRI. This Certificate shall only be used for individual, personal and confidential reference purposes. The contents of this Certificate may not, in whole or in part, be reproduced; copied; disseminated; entered into a computer database; or otherwise utilized, in any form or manner or by any means, except for the user's individual, personal and confidential reference.

CERTIFICATE VERIFICATION

The information for the model cited on this certificate can be verified at www.ahridirectory.org, click on "Verify Certificate" link and enter the AHRI Certified Reference Number and the date on which the certificate was issued, which is listed above, and the Certificate No., which is listed at bottom right.

©2021 Air-Conditioning, Heating, and Refrigeration Institute



we make life better™

CERTIFICATE NO.:

132714461428567442

U.S. Government

Federal law prohibits removal of this label before consumer purchase.

ENERGYGUIDE

Central Air Conditioner
Cooling Only
Split System

MRCOOL
Model MDUCO18024036

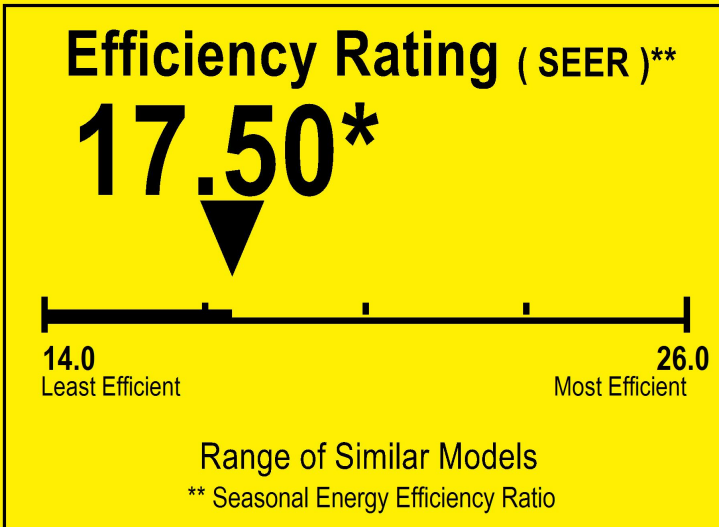

For energy cost info, visit
productinfo.energy.gov

* Your air conditioner's efficiency rating may be better depending on the coil your contractor installs.

Notice

Federal law allow this unit to be installed in all U.S. states and territories.

Energy Efficiency Ratio(EER): The installed system's minimum EER is 12.20.



ADVANCED
DC INVERTER
TECHNOLOGY

Universal[®] Series

COOLING ONLY CONDENSER
Up to 20 SEER Cooling System

MRCOOL[®] would like to announce the addition of a new cooling-only condenser to the Universal[®] line of products. If you're looking for the cooling efficiency of a Universal[®] Condenser, but live in a higher climate area where the added cost and complexity of a system with heat is not necessary, the cooling-only condenser is for you. Available in either 2-3 ton or 4-5 ton capacity configuration, this condenser offers exactly what you need and nothing you don't.

Benefits & Features



- ✓ 3 Connection Types:
 - Patented* Pre-charged No-Vac® Quick Connect® Line Set (15 ft, 25 ft, 35 ft, 50 ft-Couplings also available)
 - Sweat Braze Fitting
 - Flare Fitting
- ✓ High Efficient Energy Saving DC Fan Motor
- ✓ 2-Step Condensation Protection
- ✓ Internal Fan Blade Creates Low Noise
- ✓ Condenser Can Be Field Converted to 2-Ton from 3-Ton or 4-Ton from 5-Ton using a Dip Switch Setting (see manual for details)
- ✓ Sizes: 2-3 Ton or 4-5 Ton
- ✓ 10-Year Limited Warranty*
- ✓ The Special Fire-Proof Electrical Box Design Offers Anti-Electric Shock Reserved Installation Space for the Circuit Breaker
- ✓ Uses Environmentally-Friendly R-410A Refrigerant

Our cooling-only condenser with a DC inverter compressor is the newest addition to the Universal® line of products in 2-3 Ton or 4-5 Ton sizes. Customers who are looking only for the cooling efficiency of a Universal® Condenser can leverage this superior product as their perfect home comfort solution.

Of course, those who want cooling-only can still pair this Universal® condenser with an energy-efficient gas furnace option from our Signature Series 95% line to get high-quality heating as well. And since it is non-communicating, this could be an ideal product for homeowners who have a relatively new gas furnace they want to match with variable-speed Universal® technology.



Pat: <https://www.mrcool.com/mrcool-patents/>

SPECIFICATION

UNIVERSAL® COOLING ONLY CONDENSER

MODEL NO.	UNITS	MDUCO18024	MDUCO18036	MDUCO18048	MDUCO18060
-----------	-------	------------	------------	------------	------------

CAPACITY & PERFORMANCE

Cooling Capacity	Btu/h (kW)	24,000 (7 kW)	36,000 (10.55 kW)	48,000 (14 kW)	54,000 (15.83 kW)
SEER	Btu/w	Up to 20	Up to 18	Up to 18	Up to 17
Heating Capacity	Btu/h	N/A	N/A	N/A	N/A
EER	(Btu/h)/W	12.5	12.2	11.7	11.7
HSPF	Btu/w	N/A	N/A	N/A	N/A
Noise level - Air Handler	dB(A)	55	57	58	58

ELECTRICAL PARTS

Min/Max Voltage	V	187/253	187/253	187/253	187/253
Rated Voltage	V	208/230	208/230	208/230	208/230
Min. Current Ampacity (MCA)	A	24	24	35	35
Max. Current Over Protection (MOP)	A	35	35	45	45

DIMENSIONS & WEIGHT

Net Dimension	(L x W x H)	inch (mm)	37 x 18-1/8 x 32-1/4 (940 x 460 x 820)	37 x 18-1/8 x 32-1/4 (940 x 460 x 820)	37 x 12-5/8 x 56-3/8 (940 x 320 x 1430)	37 x 12-5/8 x 56-3/8 (940 x 320 x 1430)
Packing Dimension	(L x W x H)	inch (mm)	42-5/8 x 22-5/8 x 38-1/4 (1083 x 573 x 973)	42-5/8 x 22-5/8 x 38-1/4 (1083 x 573 x 973)	40-7/8 x 17-1/4 x 62-1/4 (1038 x 438 x 1580)	40-7/8 x 17-1/4 x 62-1/4 (1038 x 438 x 1580)
Net weight	Indoor	lbs (kg)	185.2 (84)	185.2 (84)	262 (119)	262 (119)
Gross Weight	Indoor	lbs (kg)	208.3 (94.5)	208.3 (94.5)	289 (131)	289 (131)

REFRIGERANT & PIPING

Refrigerant Type	oz	R-410A	R-410A	R-410A	R-410A
Connection Pipe Method		Quick Connect®, Flare, Weld (with Stub)	Quick Connect®, Flare, Weld (with Stub)	Quick Connect®, Flare, Weld (with Stub)	Quick Connect®, Flare, Weld (with Stub)



* Data provided by AHRI



- ☑ Kink Resistant for Easier Bending During Installation.
- ☑ 100% Accurately Precharged R-410A Refrigerant standard sizes: 15 ft, 25 ft, 35 ft, 50 ft.
- ☑ Optional No-Vac® Couplers can be used to combine two standard line sets to extend the length if needed.
- ☑ Simple to Use, Leak Proof, and Screw-on Quick Connect Valves do not require vacuuming.
- ☑ Quicker Installation than Conventional Line Sets.
- ☑ Strong 3/4 inch Gator-Flextra™ UV Protective Insulation provides extra protection against sun damage, weather erosion, or destruction from animals or insects.

NO-VAC®
Quick-Connect®
Pre-Charged
Line Set





**48 Remington Way
Hickory, KY 42051**

**Phone: 270-366-0457
www.mrcool.com**

***Display Images for demonstrative purposes only. Actual images during product use may vary.**

NOTICE: MRCOOL® products must be installed in accordance with all applicable local, state and federal codes and regulations. Unless explicitly stated otherwise, installation must be completed by a licensed / certified HVAC technician. ALL electrical connections to a power source must be performed by a licensed electrician and comply with local, state and federal electrical codes and regulations.

Please read this manual carefully before installation and keep it for future reference.

Owner's Manual



MRCOOL®

COMFORT MADE SIMPLE

Universal® Series DC Inverter / Condenser (Cooling Only) MDUC018*

Due to updates and constantly improving performance, the information and instructions within this manual are subject to change without notice. Please visit www.mrcool.com/documentation to ensure you have the latest version of this manual.

Version Date: 10-25-21

Thank you for choosing MRCOOL Please read this manual carefully before installation and keep it for future reference.

! Safety Precautions 2

1 Appliance Overview 5

- 1. Introduction 5
- 2. Accessories 6
- 3. Operating Range 7
- 4. Unit Dimensions 7



2 Unit Installation 9

- 1. Installation Location..... 9
- 2. Outdoor Installation 14
- 3. Conventional Line Set Installation..... 15
- 4. No-Vac® Quick Connect®* Installation . 24
- 5. Installation of Drain Pipe..... 25
- 6. Condenser Field Conversion..... 26
- 7. Electrical Connection..... 27

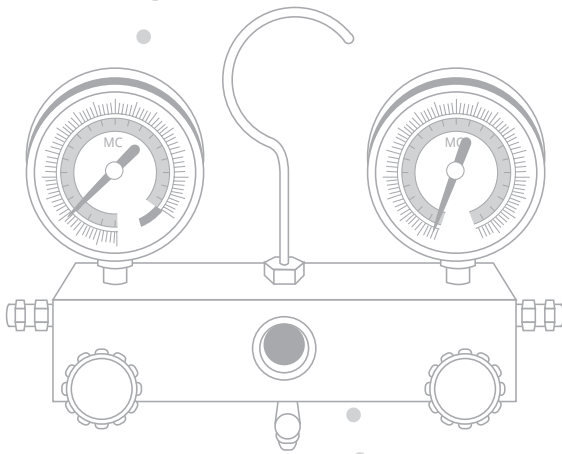

3 Post Installation Checks 32

4 Maintenance34

- 1. Troubleshooting 34
- 2. Error Codes 36
- 3. Unit Maintenance 37
- 4. Notice on Maintenance 39
- 5. After Sales Services 42

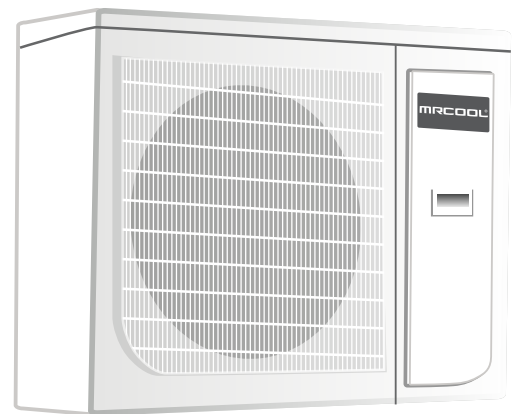

5 EU Disposal Guidelines 43

*Pat. <https://mrcool.com/mrcool-patents/>

Safety Precautions



Read Before Installation

Incorrect installation may cause serious damage or injury.

The seriousness of potential damage or injuries is classified as either a **WARNING** or **CAUTION**.



WARNING

This symbol indicates ignoring instructions may cause death or serious injury.



CAUTION

This symbol indicates that ignoring instructions may cause moderate personal injury, damage to your unit, or other property.



This symbol indicates that you should ***never*** perform the indicated action.



WARNING

Please read the manual in its entirety before installing, operating or repairing.

- ⊘ ***DO NOT*** share the electrical circuit with other appliances. Improper or insufficient power supply can cause fire or electrical shock.
 - ⊘ ***DO NOT*** let other substances or gases enter the unit when connecting refrigerant piping. The presence of other gases or substances will lower the unit's capacity, and could cause abnormally high pressure in the operation cycle. This could cause an explosion and/or personal injury.
 - ⊘ ***DO NOT*** connect the ground wire to a gas pipe, water pipe, lightning arrester, or telephone wire.
 - ⊘ ***DO NOT*** allow children to play with the air conditioner. Children should be supervised around the unit at all times.
 - ⊘ ***DO NOT*** alter the settings of the pressure sensor or other protective devices; if short-circuited or modified, fire and/or an explosion could occur.
1. Installation must be performed by an authorized technician. Improper installation could cause water leakage, electrical shock, and/or fire.
 2. Installation must be performed according to installation instructions. Improper installation could cause water leakage, electrical shock, and/or fire.
 3. In North America, installation must be performed in accordance with the requirement of NEC and CEC (by authorized personnel only). Contact an authorized service technician for repair or maintenance of the unit.
 4. Only use the included accessories and specified parts for installation. Using non-standard parts could cause water leakage, electrical shock, fire, and/or cause the unit to fail.
 5. Before installing, modifying, or servicing the system, the main electrical disconnect switch must be in the "OFF" position. There could be more than one disconnect switch. Lock out and tag switch with a suitable warning label.

WARNING

6. Install the unit in a firm location that can support the unit's weight. If the installation location cannot support the weight, or the installation is performed improperly, the unit may fall and cause serious injury and/or damage.
7. For all electrical work, follow all appropriate wiring standards, regulations, and the installation manual.
8. You must use an independent circuit to supply power. **DO NOT connect other appliances to the same circuit. Insufficient electrical capacity or defects in electrical work can cause electrical shock and/or fire.**
9. Connect electrical cables tightly and securely to the terminal board to prevent external forces from damaging the terminal.
10. All wiring must be properly arranged to ensure that the control board cover can close properly. If the control board cover is not closed properly, it can lead to corrosion and cause the connection points on the terminal to overheat, which could cause fire and/or electrical shock.
11. In certain functional environments (such as kitchens and server rooms), the use of specially designed air-conditioning units is highly recommended. If the power or thermostat wires are damaged, they must be replaced by an authorized technician in order to avoid hazard.
12. This appliance can be used by children (aged 8 years and above) and persons with reduced physical, sensory or mental capabilities or lack of experience and knowledge only if they have been given supervision or instruction concerning use of the appliance and understand the hazards involved. Children should not play with the appliance. Cleaning and user maintenance should not be performed by children.
13. The air conditioner unit can only be cleaned after it has been turned off and disconnected from the power source, otherwise electric shock could occur.
14. If installed in a compact space, ensure that there is adequate ventilation in case of leakage. A concentration of refrigerant gas could lead to an explosion and other hazards.
15. The fixed wires connecting to this appliance must be configured with an all-pole disconnect under voltage class III.
16. Wear safety glasses, protective clothing, and work gloves during installation. Also, have a fire extinguisher available in case of an emergency.
17. Always use a quenching cloth for brazing operations.

Note about Fluorinated Gases:

1. This air-conditioning unit contains R-410A fluorinated gases.
2. The refrigerant gas may not have an odor, so this should not be considered a means of leak detection.
3. Installation, service, maintenance, and repair of this unit must be performed by a certified technician.
4. Product un-installation and recycling must be performed by a certified technician.
5. If the system has a leak-detection system installed, it should be checked for leaks at least every 12 months.
6. Keep a record of all leak checks for the lifetime of the unit.

CAUTION

- ① ***DO NOT*** install the unit within 3 feet (1 meter) of combustible materials if the unit is equipped with an auxiliary electric heater.
 - ① ***DO NOT*** install the unit in a location that may be exposed to combustible gases. If combustible gas accumulates around the unit, it could cause fire and/or an explosion.
 - ① ***DO NOT*** operate your air conditioner in a room where it could be exposed to excessive amounts of water, such as a bathroom or laundry room. This could cause electrical components to short circuit.
 - ① ***DO NOT*** put appendages or other objects into the air inlet or return grills.
 - ① ***DO NOT*** stop the appliance by directly cutting off the power. Turn off the unit first.
 - ① ***DO NOT*** install the appliance in areas with the following:
 - oil smoke or volatile liquid, as plastic parts may deteriorate, adversely affecting the integrity and functionality of the appliance.
 - or corrosive gas; as this may corrode copper piping and welds, adversely affecting the integrity and functionality of the appliance.
 - ① ***DO NOT*** force-dry the filter using an open flame or blowers, as this could damage it.
 - ① ***DO NOT*** operate the air conditioner with wet hands.
 - ① ***DO NOT*** wash or sprinkle water on the air conditioner, otherwise a malfunction and/or electric shock could occur.
1. This appliance must be properly grounded during installation, or electrical shock could occur.
 2. Install drainage piping according to the instructions in this manual. Improper drainage could cause water damage to your home and property.
 3. This appliance must be stored in a well ventilated area equal in size to the area specified for operation. It must also be without a continuously operating open flame (ex. an operating gas appliance) and ignition sources (ex. an operating electric heater).
 4. Use proper measures to protect the outdoor unit from rodents and other small animals that could damage electrical components, causing the unit to malfunction.
 5. If wired control (i.e. a wall-mount thermostat) is to be used, it should be connected first before powering up the unit, otherwise it may not function properly.
 6. Only use a soft dry cloth or, as necessary, a slightly wet cloth with neutral detergent to clean the casing of this appliance.
 7. Before operating the unit under low temperature, connect it to power for 8 hours. If it is deactivated for a short time, for example, one night, do not cut off the power (this is to protect the compressor).
 8. If the unit is to be installed in a small space, please adopt protective measures to prevent the concentration of refrigerant from exceeding the allowable safety limit; excessive refrigerant leakage could lead to an explosion.
 9. When installing or re-installing the air conditioner, please keep the refrigerant circuit away from substances other than the specified refrigerant, such as air. Any presence of foreign substances will cause an abnormal pressure change or even an explosion, resulting in injury.
 10. Please adopt safety protection measures before touching the refrigerant pipe; otherwise injury could occur.
 11. Please select the properly-sized copper piping according to the requirements for pipe thickness.

To Our Customers;

Thank you for choosing a MRCOOL® home HVAC product. Please read this manual carefully before installation and operation of the Universal® Series Cooling-Only Condenser to ensure correct use and handling. In addition to the safety precautions in the previous section, please adhere to the following guidelines and note our exceptions to liability.

1. This appliance can be used by children aged 8 years and older and persons with reduced physical, sensory or mental capabilities, or lack of experience and knowledge if they have been given supervision or instruction concerning use of the appliance and understand the hazards involved. Children should not play with the appliance. Cleaning and user maintenance should not be performed by children.
2. To ensure product reliability, the unit may consume power under stand-by status to maintain normal communication, and for preheating refrigerant and lubricant. If the unit will not be used for an extended period, disconnect the power supply. Reconnect the power supply and preheat the unit prior to use.
3. Ensure you have selected the proper model for the operating environment. Improper selection may impact operating performance.
4. This product has undergone strict inspection and operational testing before leaving the factory. In order to avoid damage due to improper disassembly, which may impact the normal operation, please do not disassemble the unit without the proper training and/or equipment.
5. For technical assistance, please contact MRCOOL® technical support, at (270) 366-0457.
6. If the product is malfunctioning and/or is inoperable please contact MRCOOL® technical support, at the aforementioned number, as soon as possible and provide the following information:
 - a. Product Nameplate Contents (model number, cooling/heating capacity, product serial number, factory date)
 - b. Nature of Malfunction (specify the circumstances before and after the error occurred)
7. All illustrations and information in the instruction manual are for reference only. In order to improve the product, we will continuously assess and innovate. We retain the right to make necessary revisions to the product from time to time. We reserve the right to revise the contents of this manual without notice.
8. If the supply cord is damaged, it must be replaced by MRCOOL®, a professional service agent, or a similarly qualified person in order to avoid damage to the product.
9. MRCOOL®, LLC assumes no responsibility for personal injury, property loss or equipment damage caused by improper installation and commissioning, unnecessary maintenance, or failure to follow relevant federal and state regulations, industrial standards, and the requirements of this instruction manual.
10. MRCOOL®, LLC will bear no responsibilities for personal injury or property damage caused by the following:
 - a. Improper use of the appliance
 - b. Altering, maintaining, or operating the product with non-approved equipment.
 - c. Altering, maintaining, or operating the product outside of the guidelines of this manual.
 - d. Defects caused by corrosive gas.
 - e. Defects caused by shipping damage.
 - f. Failure to abide by this instruction manual or government regulations.
 - g. Products made by other manufacturers
 - h. Natural disasters, improper installation environment, or force majeure.

Appliance Overview

Unless otherwise stated (as "OPTIONAL") the air conditioning system includes the following accessories. Use all of the installation parts and accessories to install the air conditioner. Improper installation may result in water leakage, electrical shock, fire, and/or equipment failure.





PART	LOOKS LIKE...	QUANTITY
Owner's Manual		1
Drain Plug		3 To plug the unused drain hole
Drainage Connector		1 To connect with the PVC drain pipe
OPTIONAL No-Vac® Quick Connect® Line Set* Gas / Liquid Pipe Assembly		1
Liquid Side Stub Kit		1 To connect the unit with the liquid pipe
Gas Side Stub Kit		1 To connect the unit with the gas pipe

Fig. 1.1

Additional Line Sets & Coupler Kit				
 <p>If you find the standard size NO-VAC® QUICK CONNECT® LINE SET length is not sufficient for your application, additional line sets are available for purchase. You will also need a NO-VAC® COUPLER kit (pictured), which allows line sets to be connected together to increase the length. The coupler kit is installed and checked for leaks by following the same steps described in this manual for connecting the line set to the indoor air handler (Refer to the NO-VAC® QUICK CONNECT® Line Set section on pg. 24 for these steps).</p>				
NO-VAC® QUICK CONNECT® LINE SET Lengths Available	15 FT	25 FT	35 FT	50 FT

*Pat. <https://mrcool.com/mrcool-patents/>

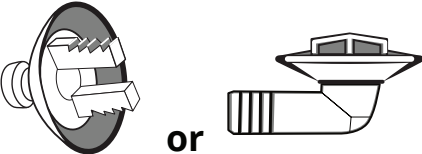
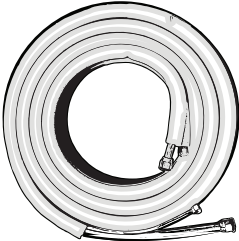
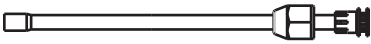
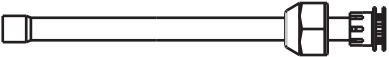
Appliance Overview

Operating Range	COOLING	HEATING
Outdoor Temperature	39.2°F(4°C) ~ 118.4°F (48°C)	N/A

Unit Dimensions of 2-3 Ton Condenser

MDUCO18024036

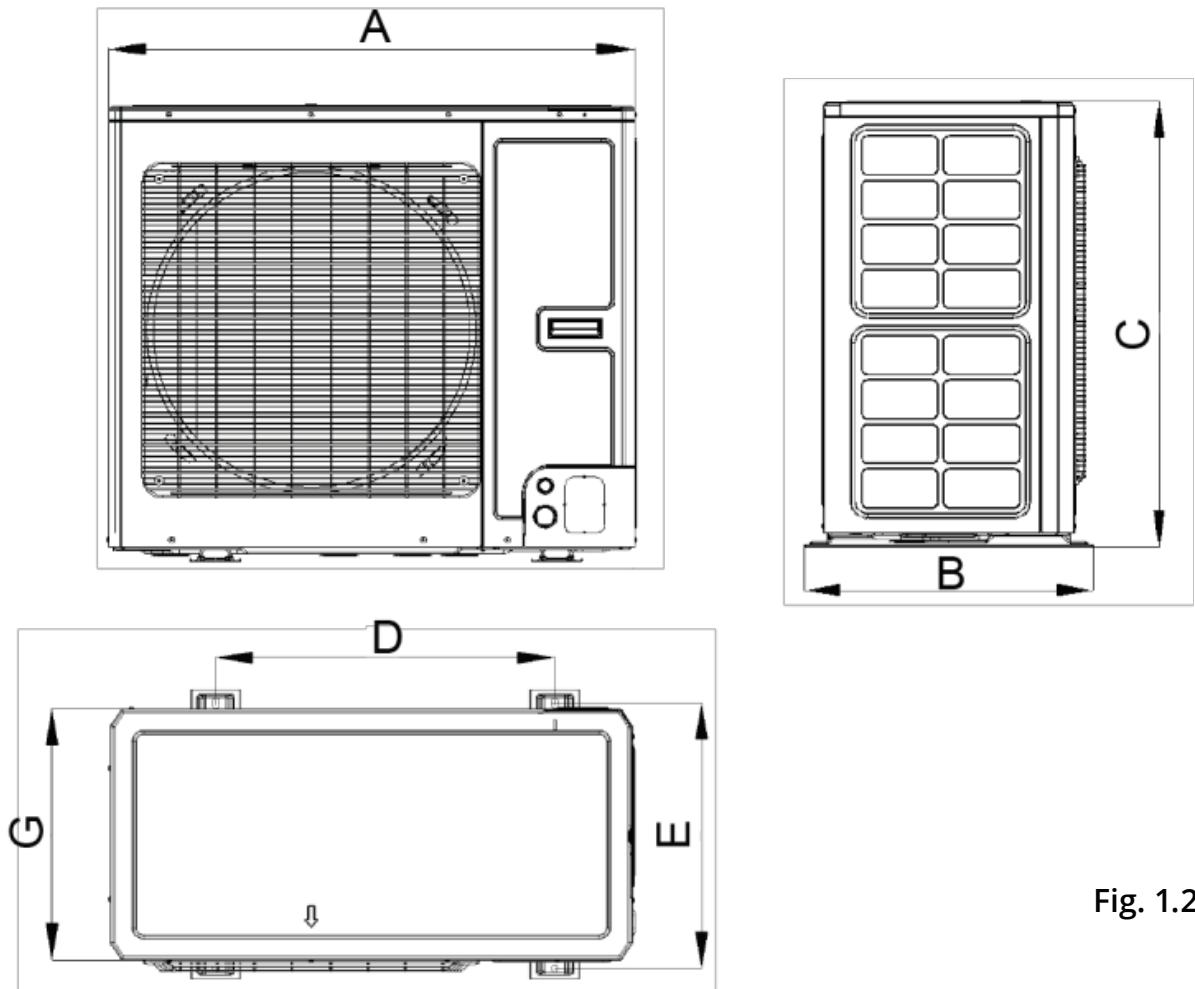

Fig. 1.2

Model	Outdoor Unit Dimensions Width (A) x Height (C) x Depth (G)	Mounting Dimensions	
		Width (A / D)	Depth (B / E)
MDUCO18024036	37 in x 32-1/4 in x 18-1/8 in. 940 mm x 820 mm x 460 mm	37 in / 24 in 940 mm / 610 mm	20-7/8 in / 19-1/8 in 530 mm / 486 mm

Appliance Overview

Operating Range	COOLING	HEATING
Outdoor Temperature	39.2°F(4°C) ~ 118.4°F (48°C)	N/A

Unit Dimensions of 4-5 Ton Condenser

MDUCO18048060

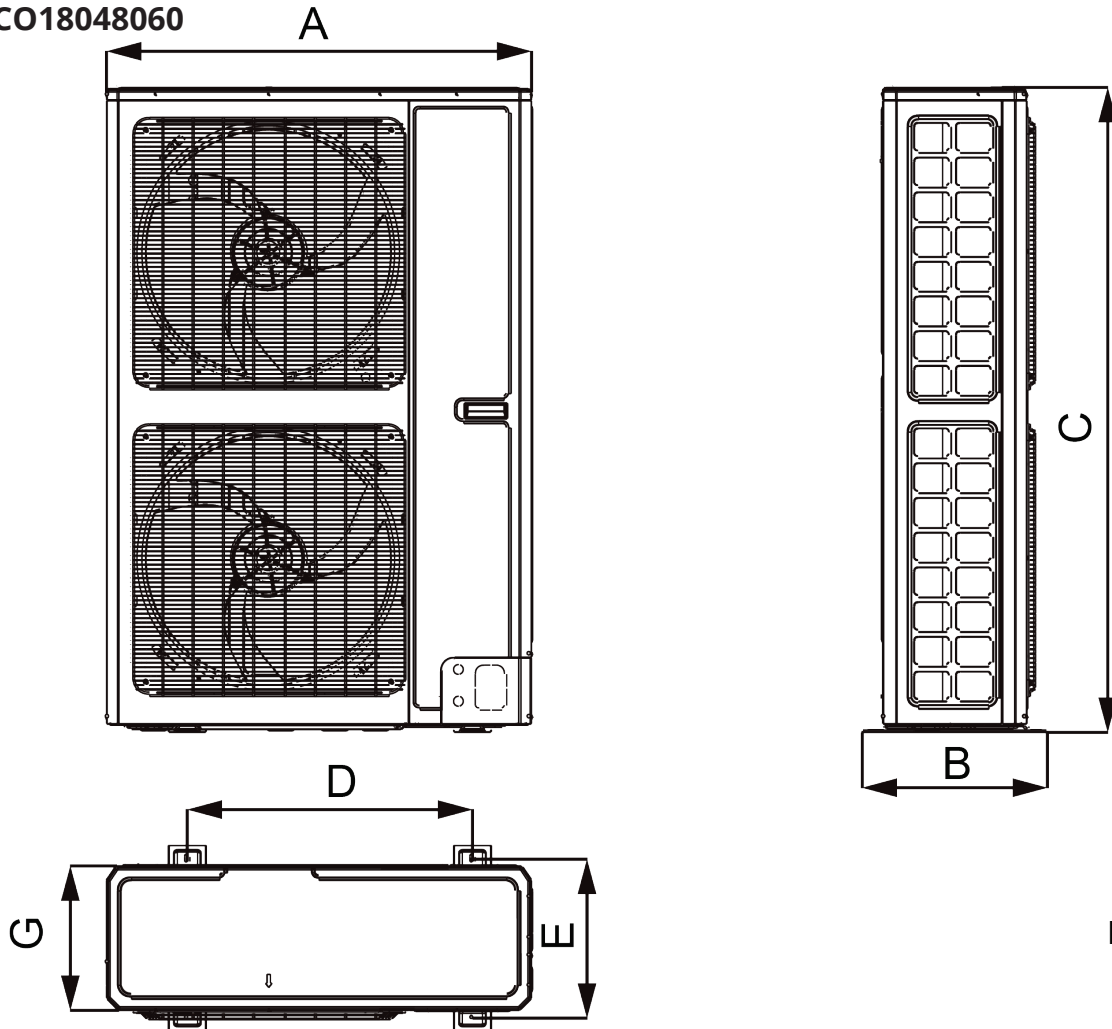

Fig. 1.3

Model	Outdoor Unit Dimensions	Mounting Dimensions	
	Width (A) x Height (C) x Depth (G)	Width (A / D)	Depth (B / E)
MDUCO18048060	37 in x 56-3/8 in x 12-5/8 in 940 mm x 1430 mm x 320 mm	37 in / 24-7/8 in 940 mm / 632 mm	16-1/8 in / 13-7/8 in 410 mm / 353 mm

! The Universal™ Series has 2 installation methods

1. The Conventional Weld Line Set Installation

Instructions can be found on **pages 15 - 23**

OR

View complete install video by scanning this QR code



MRCOOL®
Preferred Method

2. No-Vac® Quick Connect® Line Set* Installation

Instructions can be found on **page 24**

OR

View complete install video by scanning this QR code



***Pat. <https://mrcool.com/mrcool-patents/>**

Installation Location



WARNING

⚠ DO NOT install the unit where combustible gas leakage may occur.

1. The unit must be installed in a location strong enough to support the weight of the unit and fixed securely, to avoid toppling.
2. Install the appliance in a location where there is an incline of less than 5°.
3. The outdoor unit does not have a TXV (thermal expansion valve), please make sure there is a throttling valve in the indoor unit (on the air handler or "A" coil).

Select an installation location for the outdoor unit pursuant to the following conditions:

1. Noise and airflow produced by the outdoor unit will not disturb neighbors.
2. The location is away from animals and plants. If not, please add safety fences to protect the unit.
3. The area is well ventilated with no nearby obstacles that could obstruct airflow.
4. The location is able to support the weight and withstand the operating vibration of the unit.
5. Installation is able to be performed safely.
6. The location area is free of combustible or corrosive gas, and oil smoke.
7. Unit is able to be shielded from strong wind. Strong wind may affect the outdoor fan and lead to insufficient airflow volume, thus affecting performance.
8. Unit is away from objects which can generate or amplify noise during operation.
9. Condensate can be safely drained from the unit.

Installation Location

For best performance of the outdoor unit, make sure its installation space conforms to the following installation dimensions...

For installation of a single condenser refer to **Fig 2.1** below:

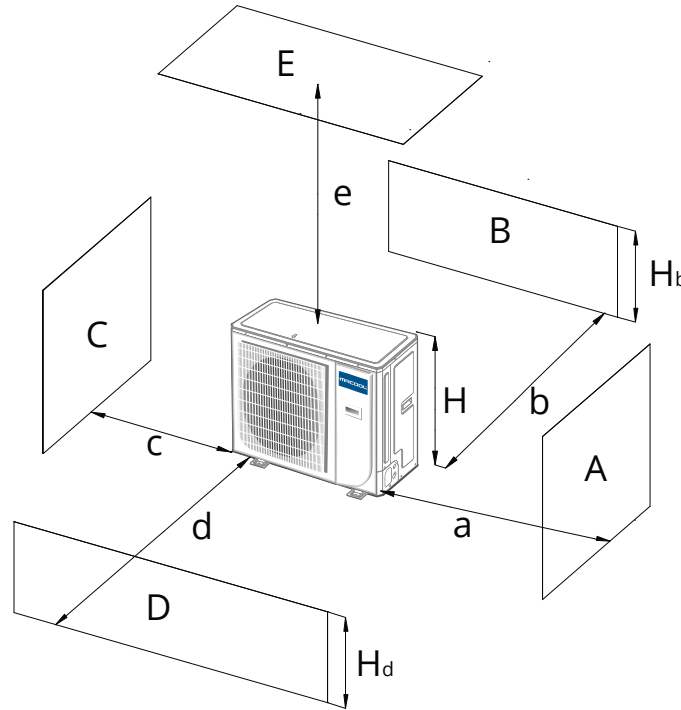

Fig. 2.1

A ~ E	H _b	H _d	H	inches (in) millimeters (mm)					
				a	b	c	d	e	
B		—			≥ 3.94 in 100 mm				
A,B,C,		—		≥ 11.81 in 300 mm	≥ 3.94 in 100 mm	≥ 3.94 in 100 mm			
B,E		—			≥ 3.94 in 100 mm			≥ 39.37 in 1000 mm	
A,B,C,E		—		≥ 11.81 in 300 mm	≥ 5.9 in 150 mm	≥ 5.9 in 150 mm		≥ 39.37 in 1000 mm	
D		—					≥ 39.37 in 1000 mm		
D,E		—					≥ 39.37 in 1000 mm	≥ 39.37 in 1000 mm	
B,D	H _b < H _d	H _d > H			≥ 3.94 in 100 mm		≥ 39.37 in 1000 mm		
	H _b > H _d	H _d < H			≥ 3.94 in 100 mm		≥ 39.37 in 1000 mm		
B,D,E	H _b < H _d	H _b ≤ 1/2H			≥ 9.84 in 250 mm		≥ 78.74 in 2000 mm	≥ 39.37 in 1000 mm	
		1/2H < H _b ≤ H			≥ 9.84 in 250 mm		≥ 78.74 in 2000 mm	≥ 39.37 in 1000 mm	
		H _b > H	Prohibited						
	H _b > H _d	H _d ≤ 1/2H				≥ 3.94 in 100 mm		≥ 78.74 in 2000 mm	≥ 39.37 in 1000 mm
		1/2H < H _d ≤ H				≥ 7.87 in 200 mm		≥ 78.74 in 2000 mm	≥ 39.37 in 1000 mm
		H _d > H	Prohibited						

Installation Location

For best performance of the outdoor unit, make sure its installation space conforms to the following installation dimensions...

For installation of multiple condensers side by side refer to **Fig 2.2** below:

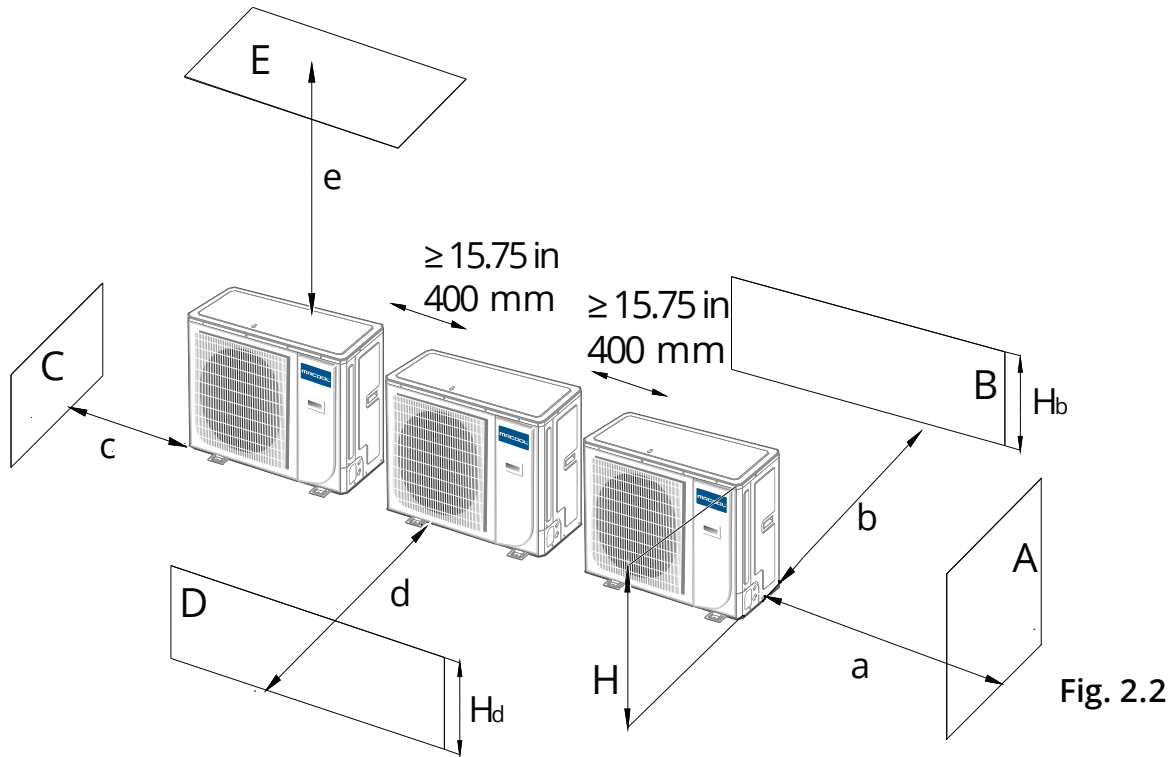

Fig. 2.2

A ~ E	H _b	H _d	H	inches (in) millimeters (mm)					
				a	b	c	d	e	
A, B, C,		—		≥ 11.81 in 300 mm	≥ 11.81 in 300 mm	≥ 39.37 in 1000 mm			
A, B, C, E		—		≥ 11.81 in 300 mm	≥ 11.81 in 300 mm	≥ 39.37 in 1000 mm		≥ 39.37 in 1000 mm	
D		—					≥ 78.74 in 2000 mm		
D, E		—					≥ 78.74 in 2000 mm	≥ 39.37 in 1000 mm	
B, D	H _b < H _d	H _d > H			≥ 11.81 in 300 mm		≥ 78.74 in 2000 mm		
	H _b > H _d	H _d ≤ 1/2H			≥ 9.84 in 250 mm		≥ 78.74 in 2000 mm		
		H _d < H			≥ 11.81 in 300 mm		≥ 98.43 in 2500 mm		
B, D, E	H _b < H _d	H _b ≤ 1/2H			≥ 11.81 in 300 mm		≥ 78.74 in 2000 mm	≥ 39.37 in 1000 mm	
		1/2H < H _b ≤ H			≥ 11.81 in 300 mm		≥ 98.43 in 2500 mm	≥ 39.37 in 1000 mm	
		H _b > H	Prohibited						
	H _b > H _d	H _d ≤ 1/2H				≥ 9.84 in 250 mm		≥ 98.43 in 2500 mm	≥ 39.37 in 1000 mm
		1/2H < H _d ≤ H				≥ 11.81 in 300 mm		≥ 98.43 in 2500 mm	≥ 39.37 in 1000 mm
		H _d > H	Prohibited						

Installation Location

For best performance of the outdoor unit, make sure its installation space conforms to the following installation dimensions...

For installation of multiple condensers in rows refer to **Fig 2.3** below:

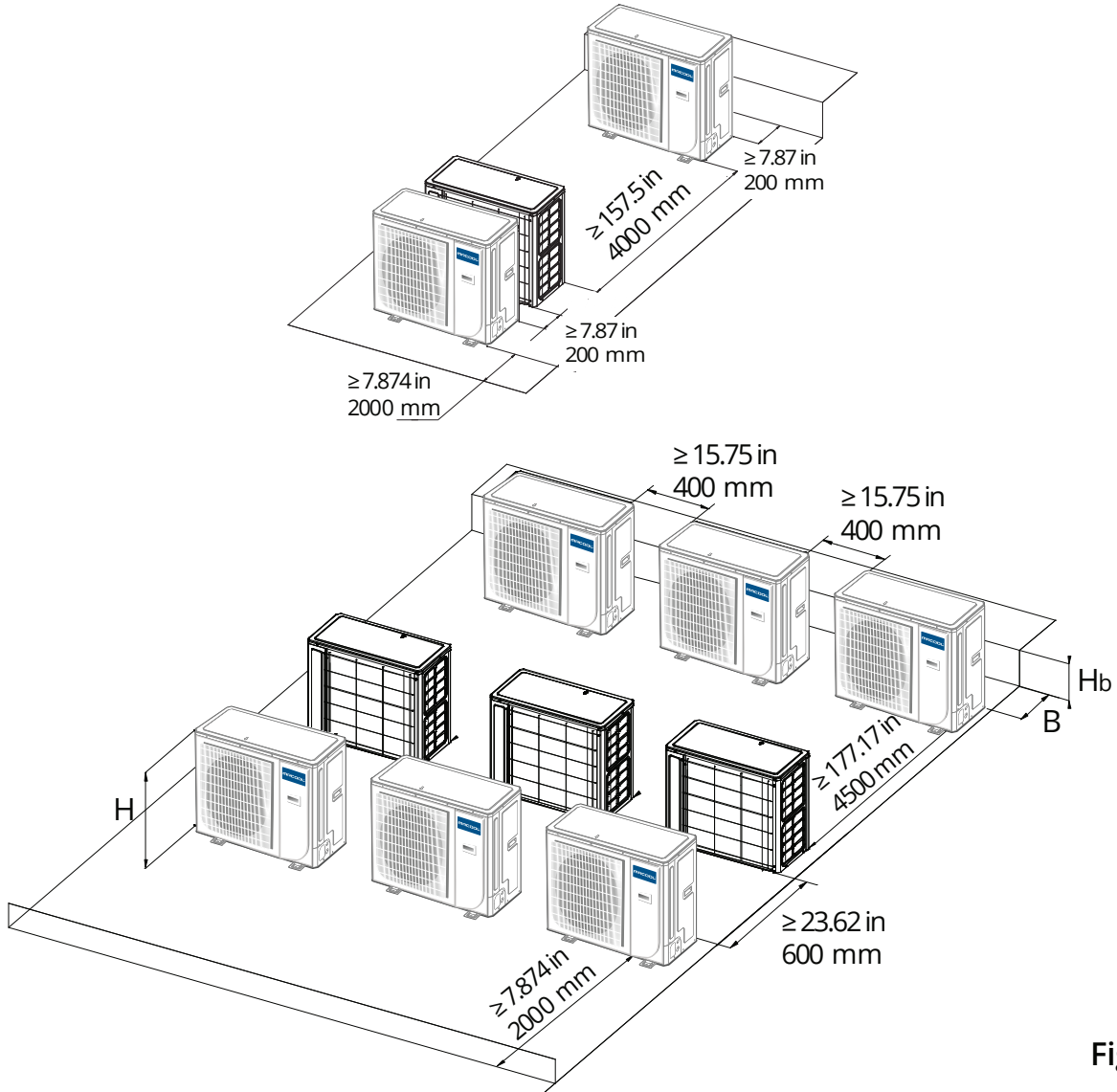

Fig. 2.3

H_b H	inches (in) millimeters (mm)
$H_b \leq 1/2H$	$b \geq 9.84$ in (250 mm)
$1/2H < H_b \leq H$	$b \geq 11.81$ in (300 mm)
$H_b > H$	Prohibited

Installation Location

For best performance of the outdoor unit, make sure its installation space conforms to the following installation dimensions...

For installation of multiple condensers on a vertical face refer to **Fig 2.4** below:

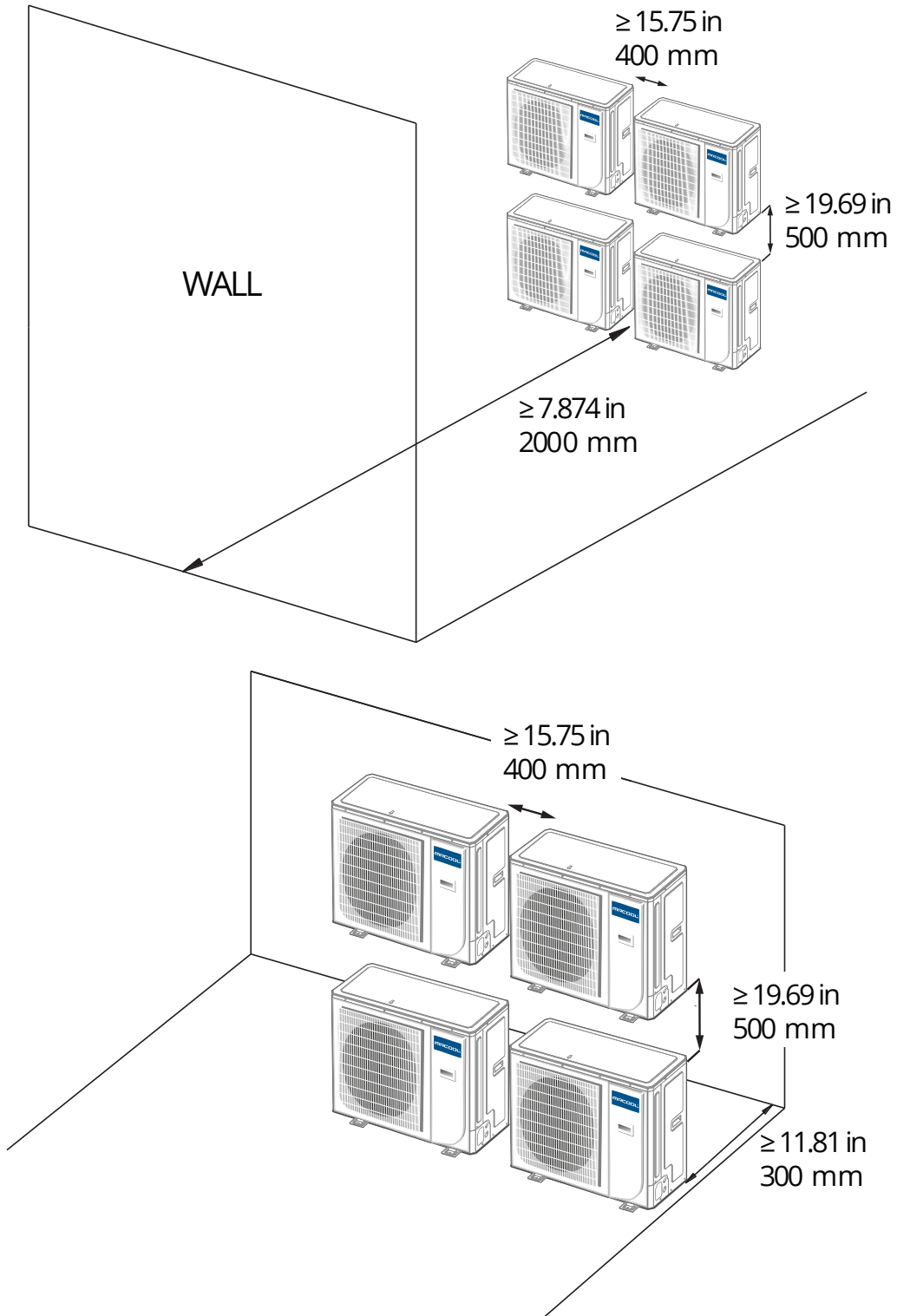

Fig. 2.4

Outdoor Unit Installation

1. If the outdoor unit is installed on a solid surface such as concrete, use M10 screw bolts and nuts to secure the unit. Make sure the unit stands erect and level.
2. If the unit vibrates and generates noise, add rubber cushions between the unit's feet and the installation surface.
3. When the outdoor unit is in heating or defrosting mode, it must drain water. When installing the drain pipe, plug the accompanied drainage connector to the drainage hole on the chassis of the outdoor unit. Then, connect the drain hose to the drainage connector. If the drainage connector is used, the outdoor unit should be at least 4 in (10 cm) from the ground.
4. Plugs and drainage connector are not recommended if there is an electrical heater on the chassis.

Refer to Fig. 2.5 for details.

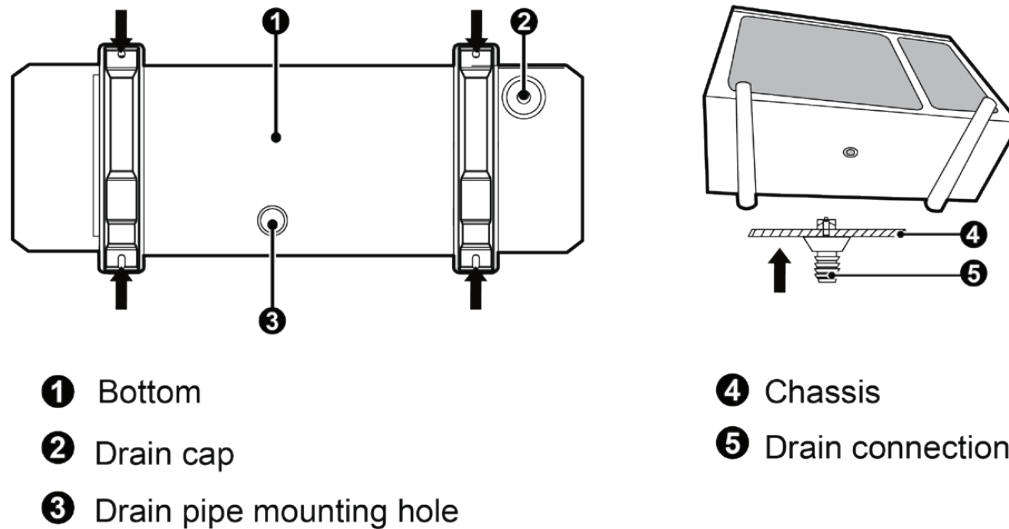

Fig. 2.5

NOTE

The outdoor condenser can also be mounted to concrete with the use of masonry anchors. Be sure to drill an appropriate sized pilot hole before attempting to screw the anchor into the concrete.



Conventional Line Set Installation

INSTALLATION METHOD

Connect the refrigerant lines to the unit first. When bending a refrigerant pipe, be careful not to kink or crimp the pipe. ***DO NOT over-tighten the flare nut, otherwise leakage may occur.*** The outside of the refrigerant pipe should have a layer of insulating cotton to protect it from mechanical damage during installation, maintenance, and transportation.

Refrigerant lines should adopt water-proof insulating material. The pipe wall thickness should be 0.5-1.0 mm and able to withstand 6.0 MPa. Excessive length of the refrigerant lines will negatively affect cooling and heating performance. Attempt to minimize refrigerant line length when possible.

When the drop between indoor and outdoor units is larger than 32 ft (10 m), an oil return bend should be added every 19.69 ft (6 m).

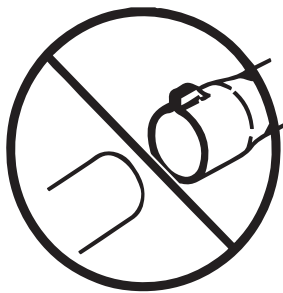
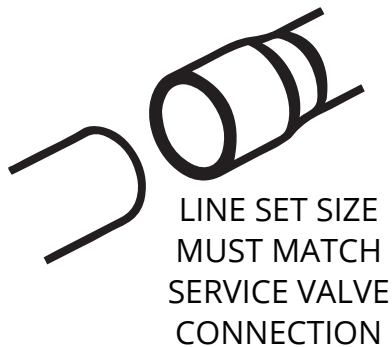

DO NOT CRIMP SERVICE VALVE CONNECTOR IF PIPE IS SMALLER THAN CONNECTOR

Outdoor Unit Model	Size of Fitting Pipe		Maximum Pipe Length	Maximum Drop between indoor and outdoor units
	Liquid Pipe	Gas Pipe		
MDUCO18024036	3/8 in	3/4 in	98.4 ft (30 m)	49.2 ft (15 m)
MDUCO18048060				

CAUTION

Be extremely careful not to dent or damage the piping while bending them away from the unit. Any dents in the piping will affect the unit's performance.

For installation with a **No-Vac® Quick Connect® Line Set**, refer to the next section starting on page 24

OIL RETURN BENDS

Add an oil return bend as described below:

- **If the outdoor unit is installed beneath the indoor unit**, install an oil return bend every 20 ft (6 m). A non-return bend is not needed in this configuration. Please refer to **Fig. 2.6** below:
- **If the outdoor unit is installed above the indoor unit**, install an oil return bend every 20 ft (6 m). It is also necessary to add a non-return bend at the lowest and highest position of the vertical pipe, as shown below in **Fig. 2.7**:

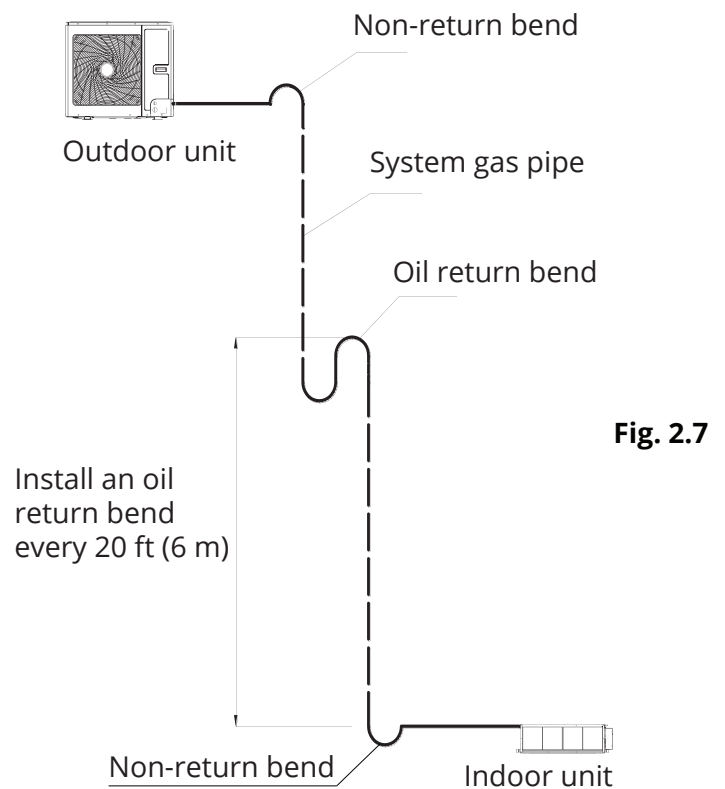
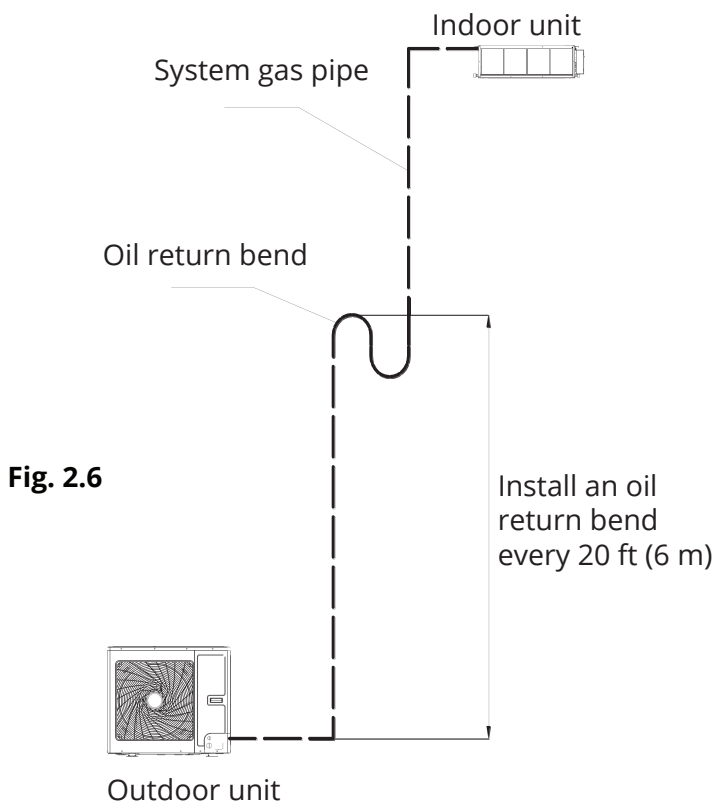

Use the following dimensions in **Fig. 2.8** to form the oil return bend(s):

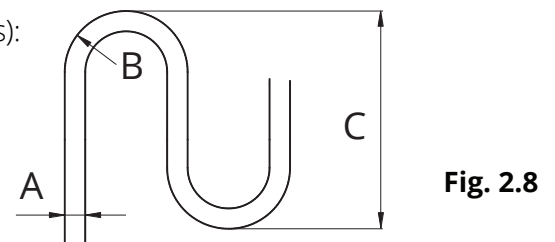

A (Pipe Diameter)		B		C	
Inches	mm	Inches	mm	Inches	mm
Φ1/2	Φ12	≥1	≥26	≥5.91	≤150
Φ5/8	Φ16	≥1.3	≥33	≥5.91	≤150
Φ3/4	Φ19	≥1.34	≥34	≥5.91	≤150

Conventional Line Set Installation

Pipe Cutting

Step 1: Cut Pipe

1. When preparing refrigerant pipes, take extra care to cut and flare them properly. This will help to ensure the piping has an airtight seal, which can affect operation efficiency and the need for future maintenance.
2. Measure the distance between the indoor and outdoor units.
3. Using a pipe cutter, cut the pipe a little longer than the measured distance.
4. Make sure that the pipe is cut at a perfect 90° angle. Refer to **Fig. 2.9** for cut examples.

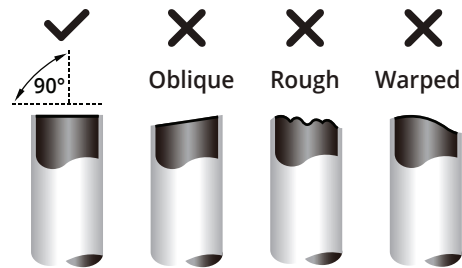

Fig. 2.9

DO NOT DEFORM PIPE WHILE CUTTING

Be extra careful not to damage, dent, or deform the pipe while cutting. This will drastically reduce the heating efficiency of the unit.

Step 2: Remove burrs

Burrs can affect the airtight seal of the refrigerant piping connection. They must be completely removed.

1. Hold the pipe at a downward angle to prevent burrs from falling into the pipe.
2. Using a reamer or deburring tool, remove all burrs from the cut section of the pipe. Refer to **Fig. 2.10**
3. After removing burrs from the cut pipe, seal the ends with PVC tape to prevent foreign materials from entering the pipe.

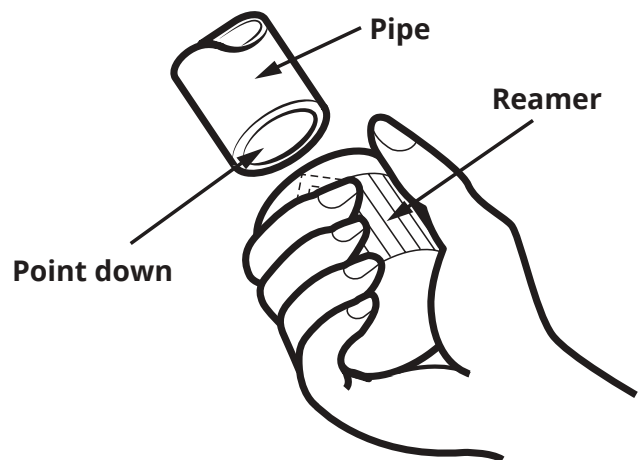

Fig. 2.10

For installation with a **No-Vac® Quick Connect® Line Set**, refer to the next section starting on page 24

Conventional Line Set Installation

Pipe Flaring

Step 3: Flare pipe ends

Proper flaring is essential to achieve an airtight seal.

1. Sheath the pipe with insulating material as necessary
2. Remove the cut-off valve of the outdoor unit and take out the flare nut from the bag of indoor unit accessories. Fit the flare nut on the pipe. See **Fig. 2.11**.
3. Make sure it is facing in the right direction, because you cannot remove the nut or change its direction once the pipe has been flared. See **Fig. 2.12**.
4. Remove PVC tape from the end of the pipe when ready to perform flaring work.
5. Clamp flare form on the end of the pipe. The end of the pipe should extend $\sim 1/16$ in (1.6 mm) beyond the edge of the flare form, as shown in **Fig. 2.14**.
6. Place flaring tool onto the form, as shown in **Fig. 2.13**.
7. Turn the handle of the flaring tool clockwise until the pipe is fully flared, as shown in **Fig. 2.13**.
8. Remove the flaring tool and flare form, then inspect the end of the pipe for cracks and even flaring.

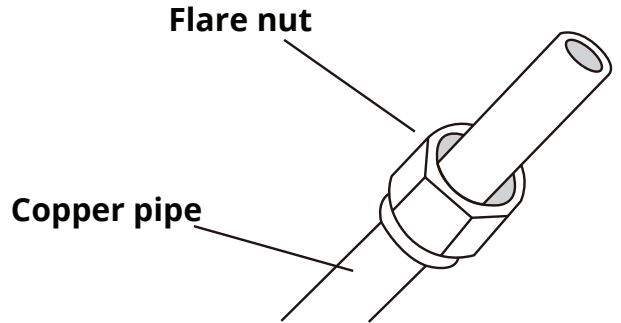

Fig. 2.11

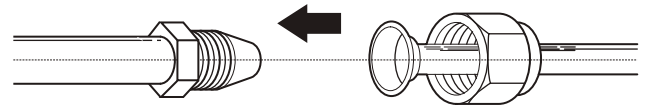

Fig. 2.12

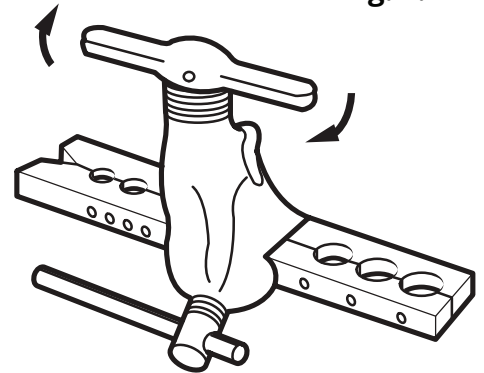

Fig. 2.13

PIPING EXTENSION BEYOND FLARE FORM

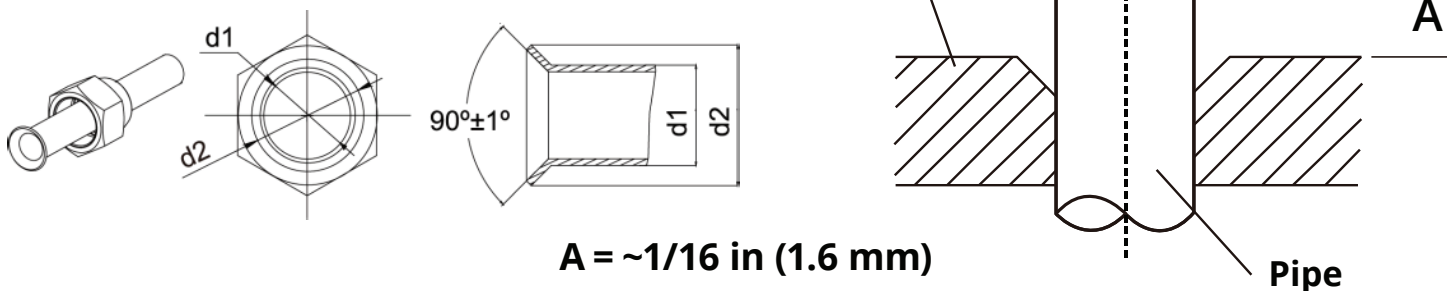

Fig. 2.14

For installation with a **No-Vac® Quick Connect® Line Set**, refer to the next section starting on page 24

Conventional Line Set Installation

Pipe Bending

1. Use your hands to bend the pipes. Work carefully not to collapse the pipes during bending.
2. If the pipe is repeatedly bent or extended, it will become hard and difficult to manipulate. Avoid bending or extending the pipe more than 3 times.

⚠ **DO NOT** bend the pipe excessively, otherwise it will break.

⚠ **DO NOT** bend the pipes at an angle greater than 90°.

MINIMUM BEND RADIUS

When bending connective refrigerant piping, the minimum bending radius is 10 cm. Refer to Fig. 2.15

Refer to Fig. 2.15

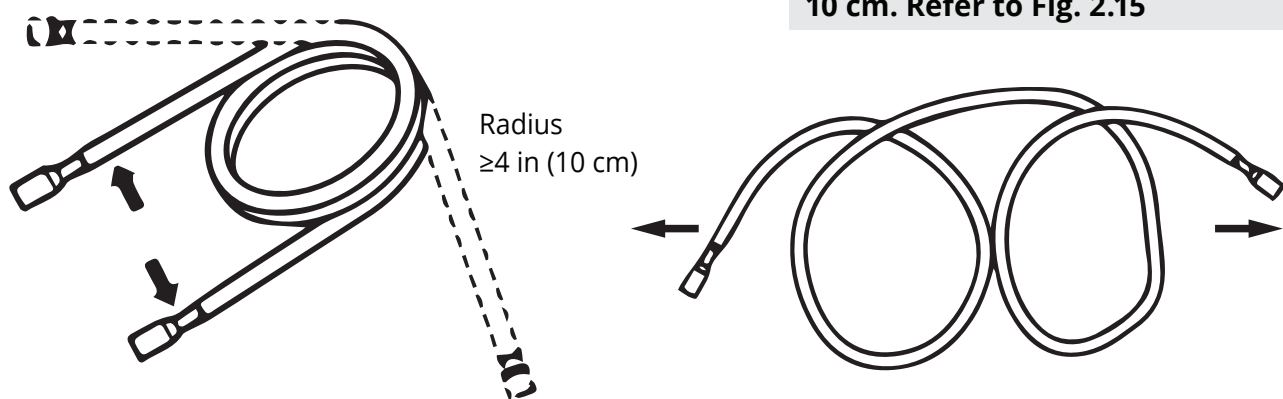

Extend the pipe by unwinding it



Fig. 2.15

3. As shown in **Fig. 2.16**, use a sharp cutter to cut the pipe insulation and bend the pipe after it is exposed. After bending the pipe to the desired angle, place the insulation back on the pipe and secure it with adhesive tape.

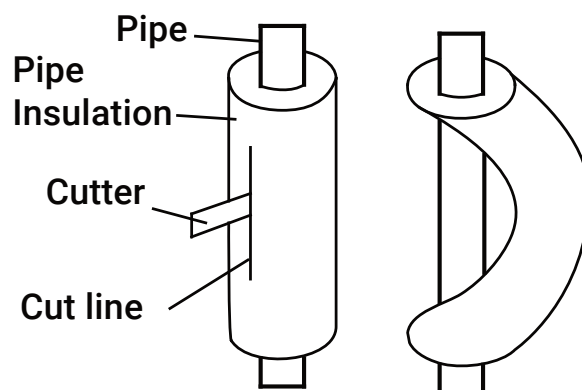

Fig. 2.16

For installation with a **No-Vac® Quick Connect® Line Set**, refer to the next section starting on page 24

Conventional Line Set Installation

Replacement Condenser Only

Fig. 2.17

MRCOOL Universal Series DC Inverter

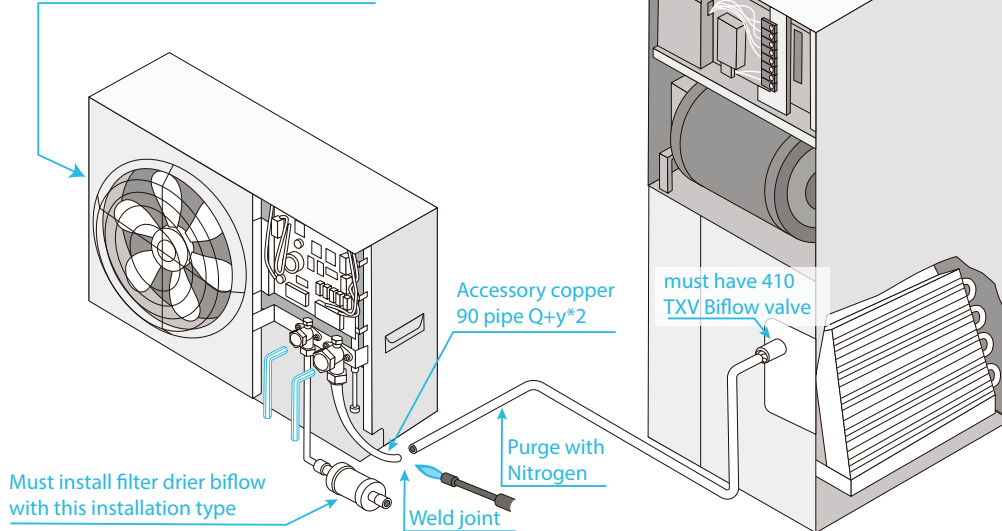

! IMPORTANT
The existing air handler in the house must be a 410 air handler and use a 410 TXV Biflow Valve

! IMPORTANT
In order to prevent the refrigerant piping from sweating, they can be insulated with closed-cell insulation foam for refrigerant line sets which is readily available.



WELD Type Complete Unit Replacement

Fig. 2.18

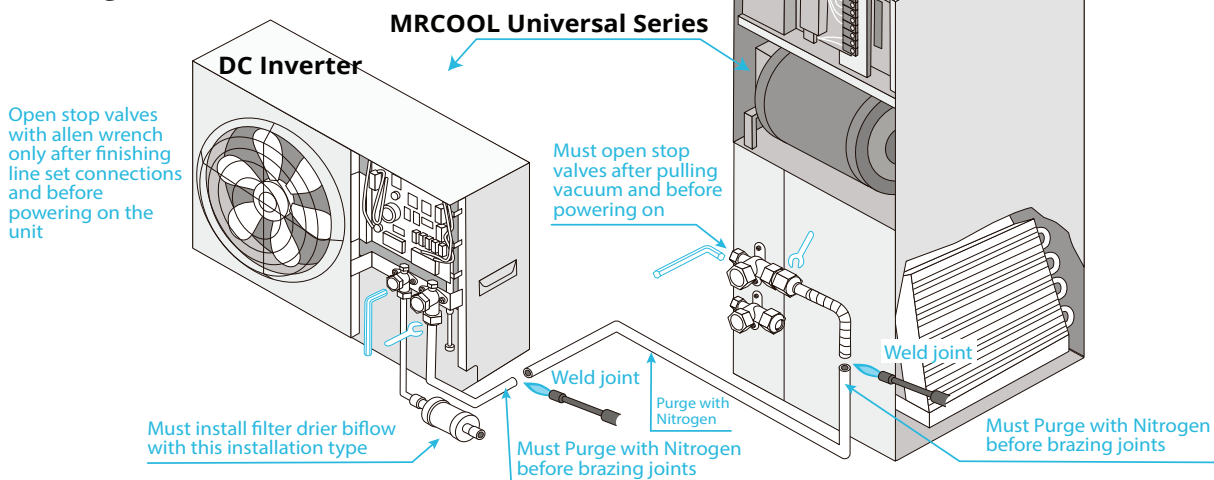

Conventional Line Set Installation

Pipe Connection

WARNING

1. Connect the pipe to the unit. Follow all instructions below. Use both a spanner and torque wrench.
2. When connecting the tapered flare nut, first apply Polyolester oil (POE oil) on its inner and outer surface and then screw the flare nut by hand 3 or 4 threads to ensure it does become crooked.
3. Be sure to connect gas pipe after the liquid pipe is connected.
4. Confirm the tightening torque by referring to the table below. Then tighten the flare nut to the specified torque using a torque wrench and spanner. **DO NOT over-tighten the flare nut. If the flare nut is overtightened, it may be damaged and cause leakage.**
5. Keep pipe connection joints exposed to perform the leak test (refer to Post Installation Checks section of this manual).
6. If there are no leaks, then apply thermal insulation to the gas piping. Wind sponge around the joint of the gas pipe and heat insulation sheath on the gas collecting pipe.
7. Insulation for the liquid piping is optional.

1. Screw the flare nut of the flared connecting pipe onto the outdoor unit valve. Refer to **Fig. 2.19A** & **Fig. 2.19B**, using the torque values in the table below.

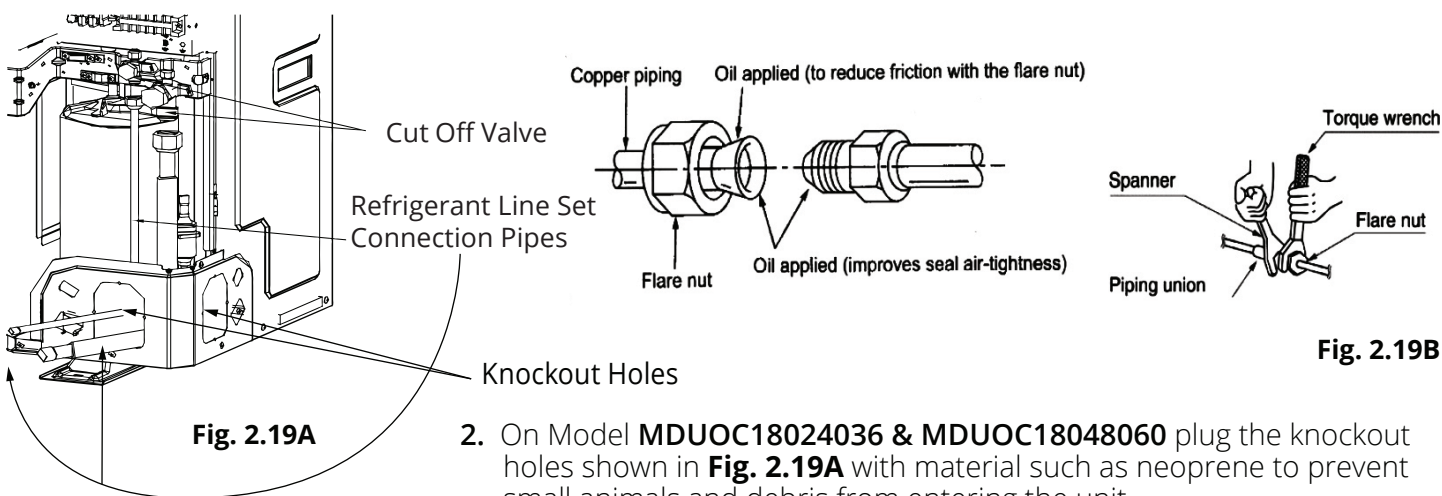

Fig. 2.19B

2. On Model **MDUOC18024036** & **MDUOC18048060** plug the knockout holes shown in **Fig. 2.19A** with material such as neoprene to prevent small animals and debris from entering the unit.

Pipe diameter (in. mm)	Tightening torque ft/lbs (N·m)
Φ1/4 in Φ6.4 mm	11-22 ft/lb (15-30 Nm)
Φ3/8 in Φ8.3 mm	26-29 ft/lb (35-40 Nm)
Φ1/2 in Φ12.7 mm	33-37 ft/lb (45-50 Nm)
Φ5/8 in Φ15.9 mm	44-48 ft/lb (60-65 Nm)
Φ3/4 in Φ19 mm	52-55 ft/lb (70-75 Nm)
Φ7/8 in Φ22.2 mm	59-63 ft/lb (80-85 Nm)

DO NOT USE EXCESSIVE TORQUE

Excessive force can break the nut or damage the refrigerant piping. You must not exceed torque requirements shown in the table.

For installation with a **No-Vac® Quick Connect® Line Set**, refer to the next section starting on page 24

Conventional Line Set Installation

Vacuum Lines

WARNING

- Make sure the outlet of the vacuum pump is away from any potential source of fire and is well ventilated.
 - Before vacuum pumping, make sure the unit cut-off valves are closed.
 - When vacuum pumping, both the liquid pipe and the gas pipe must be pumped.
1. Remove the caps on the liquid valve, gas valve, and also the service port.
 2. Connect the hose at the low pressure and high pressure sides of the manifold valve assembly to the service port of the unit's gas and liquid valve. Meanwhile, the gas and liquid valves should be kept closed to avoid a refrigerant leak.
 3. Connect the hose used for evacuation hose to the vacuum pump.
 4. Open the switches on the lower pressure side and high pressure side of the manifold valve assembly at the same time and start the vacuum pump.
 5. The evacuation duration typically depends on the unit capacity: **for Model MDUCO18024036 time is generally 30 minutes, for model MDUCO18048060 time is generally 45 minutes.** Verify that the pressure gauge on the low pressure side of the manifold valve assembly reads -0.1 Mp (-30 in Hg). If it does not, there is leak somewhere. Close the switch fully and stop the vacuum pump.
 6. Wait for 10 minutes to see if the system pressure remains unchanged. During this time, the reading of the pressure gauge at the low pressure side should not be larger than 0.005 Mp (0.15 in Hg).
 7. Open the liquid valve slightly, and allow some refrigerant to be released into the connection pipe to balance the pressure inside and outside of the connection pipe, so that air will not come into the connection pipe when removing the hose. **Note that the gas and liquid valve can be opened fully only after the manifold valve assembly is removed.**
 8. Return the caps to the liquid valve, gas valve, and service port.
 9. **For larger-sized units,** there are maintenance ports for the liquid valve and gas valve. During evacuation, you may connect the two hoses of the branch valve assembly to the maintenance ports to speed up the evacuation.

Refer to Fig. 2.20

For installation with a **No-Vac® Quick Connect® Line Set**, refer to the next section starting on page 24

Conventional Line Set Installation

Vacuum Lines

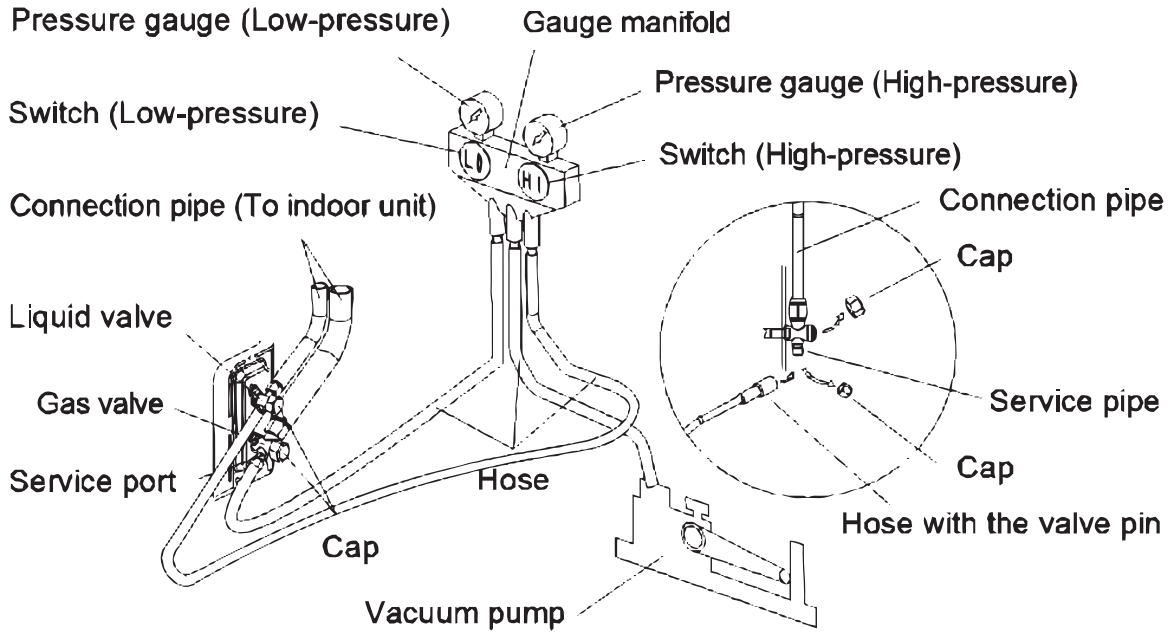

Fig. 2.20

Adding Refrigerant

Outdoor Unit Model	Standard Pipe Length	Max Pipe Length Requiring No Added Charge (Not for No-Vac Quick Connect)	Additional Refrigerant per Line Length
MDUCO18024036	24.6 ft 7.5 m	≤31.2 ft ≤9.5 m	0.32 oz/ft 30 g/m
MDUCO18048060			

For installation with a **No-Vac® Quick Connect® Line Set**, refer to the next section starting on page 24

No-Vac® Quick Connect® Line Set* Installation

INSTRUCTIONS FOR USE WITH NO-VAC™ QUICK CONNECT® LINE SET* SOLD SEPARATELY
KINK RESISTANT, PRECHARGED, SIMPLE SECURE QUICK CONNECT, 100% CONNECTION GUARANTEE

Please read and follow the instructions and diagram below* :
Connections must be made exactly as specified to avoid system leaks and /or damage

1. Take out matching male connectors **M1** and **M2**.
2. **Remove** protective cap with the copper gasket at each stop valve on the **DC INVERTER** and ensure the threads are clean and complete.
3. **Tighten** the **M1** connector to the **cutoff valve *1** with a tightening force of **37 ft/lb (50 Nm)**.
Tighten the **M2** connector to the **cutoff valve *2** with a tightening force of **52 ft/lb (70.5 Nm)**.
4. **Repeat** step 3 for **AIR HANDLER** at the other end of the **LINE SET**.
5. Unroll and route the **LINE SET** between the **AIR HANDLER** and the **DC INVERTER**. Bend the line set by hand to route the line set to suit your application. Use care when bending the line set. Please refer to **Fig. 2.15 on Pg. 19** for more detailed instructions on how to properly and safely bend refrigerant piping, as well as the correct bend radius.
6. **Remove** the protective caps of the valves at both ends of the **LINE SET**. Verify that all threads are clean and complete.
7. **Tighten** the **LINE SET F1** valve to the **M1 Connector** (attached in step 3) with a force of **33 ft/lb (45 Nm)**. **Tighten** the **LINE SET F2** valve to the **M2 Connector** (attached in step 3) with a tightening force of **48 ft/lb (65 Nm)**.
8. **Repeat** this process for the **AIR HANDLER** at the other end of the **LINE SET**.
9. At the **OUTDOOR UNIT** remove the **protective cap** at the **cutoff valve switch** and **open** the **cutoff valve** with a hex wrench to release refrigerant into the system. **If there is any fizz, grease or other leakage, then close the valve immediately and check that steps 3 and 7 were done properly. Otherwise, using a sponge or spray bottle, apply a soapy water solution to the connection points to check for micro leaks. If any bubbles form it indicates there is a leak. If this does occur, close the valve immediately and check that steps 3 and 7 were done properly and re-tighten the valves and line set if necessary.**
10. **After** the correct connection, **re-tighten** the cutoff valve's **protection cap** and **cover** the **M1, M2** and **F1, F2** connections with the gray **insulating sleeve** to help **prevent condensation**.

! IMPORTANT

When running the Line Set through the knockout hole of the condenser, it may be necessary to slightly trim the line set insulation so it feeds through the hole freely. Otherwise, it may be difficult to connect it to the condenser. Once the installation is complete, pack the hole with neoprene to prevent small animals and insects from entering the condenser.



NOTE ON WRENCHES

The wrench sizes needed for tightening the No-Vac® Quick Connect® Line Set are listed below. However, based on the availability of the wrench sizes needed, it is recommended to use two large crescent (adjustable-type) wrenches. Using one to hold the valve while using the other wrench to tighten the line set connector.

Piping Size (Stamped on piping)	Wrench Size Required	
	Standard	Metric
3/8"	1"	25 mm
3/4"	1-3/8"	35 mm

Or 2x large crescent (adjustable-type) wrenches

Allen/Hex Wrench Sizes Needed To Open Stop/Cutoff Valves	
Piping/Valve Size (Stamped on piping)	Allen Wrench Size
3/8"	5 mm
3/4"	8 mm

! IMPORTANT

The stop/cutoff valves on the unit must be opened **AFTER** connecting the lines and **BEFORE** turning on the unit. Otherwise, operation can cause leakage and/or damage to the unit.

Complete unit replacement using the No-Vac® Quick Connect® lines

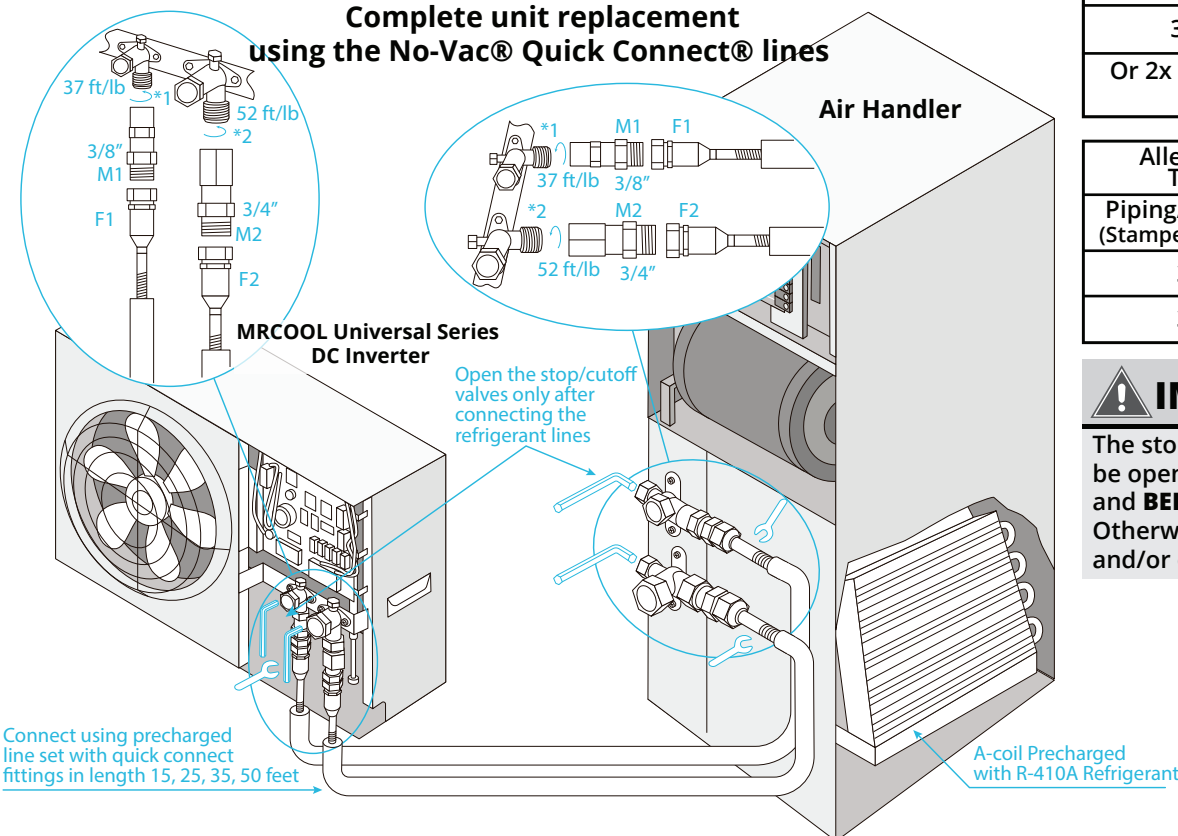

Failure to follow the instructions provided could result in severe harm to you, this product, or other property. The manufacturer, distributor, and seller are not responsible for any harm resulting from the failure to follow instructions and the failure to follow these instructions will void any and all warranties express or implied.

*Pat. <https://mrcool.com/mrcool-patents/>

www.mrcool.com

v10-25-2021

Installation of Drain Pipe

If the outdoor unit is located on a level lower than the indoor unit, arrange the condensate drain according to Fig. 2.21.

1. Drain hose should be placed on the ground and its end should not be immersed into water.
2. The entire line set, including drain pipe should be wound with insulating tape. Wrap the insulating tape from bottom to top, as this will ensure rain/moisture does not seep into the tape overlaps.
3. The entire line set, including drain pipe should be supported and fixed onto the wall with saddles.

- ① Sealed
- ② Saddle
- ③ Drain Pipe

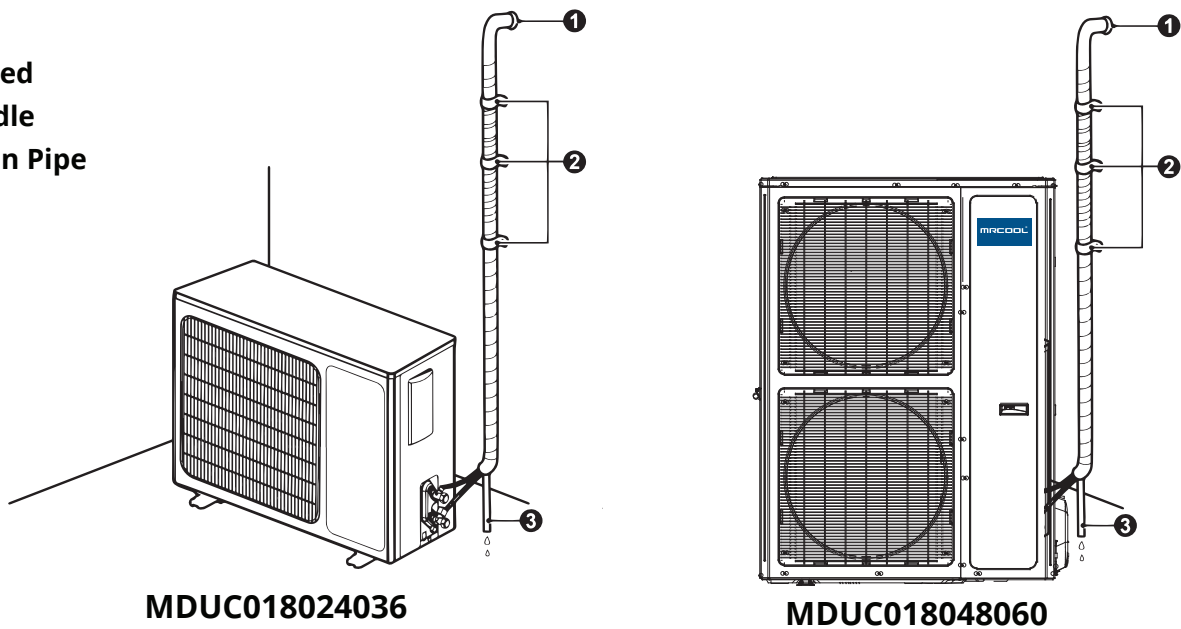

Fig. 2.21

MDUC018024036

MDUC018048060

If the outdoor unit is located on a level higher than the indoor unit, arrange the condensate drain according Fig. 2.22.

1. Drain hose should be placed on the ground utilizing a trap.
2. The entire line set, including drain pipe should be wrapped with insulating tape to avoid water returning to the interior. Wrap the insulating tape from bottom to top, as this will ensure rain/moisture does not seep into the tape overlaps.
3. The entire line set, including drain pipe should be supported and fixed onto the wall with saddles.

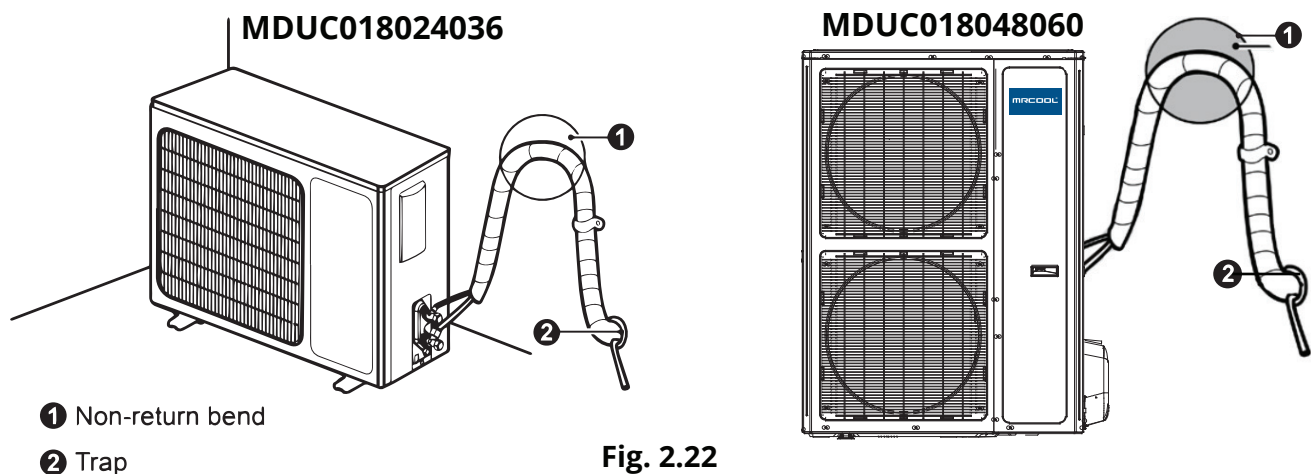

- ① Non-return bend
- ② Trap

Fig. 2.22

Condenser Field Conversion

Converting Unit From 3-Ton to 2-Ton

Follow these instructions during unit installation in order to enable a Universal® Series 3-ton condenser and air handler split system to operate at 2-ton capacity.

⚠ DO NOT attempt this conversion while the unit is powered on.

1. Locate the capacity dip switch on the condenser main board. The capacity dip switch is circled in the photo below.
2. The default position of the capacity dip switch is 1 & 2 'Up' and 3 & 4 'Down'. Up being a switch pushed toward the letters (ON DIP). Down being a switch pushed toward the numbers (1 2 3 4).
3. The default position of the capacity dip switch is 36K.
4. To activate the 24K capacity, flip capacity dip switch 1 from the Up position to the Down position.

Fig. 2.23

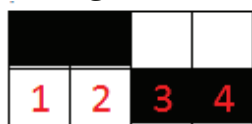

DEFAULT 3 TON

Fig. 2.24



2 TON SETTING

Converting Unit From 5-Ton to 4-Ton

Follow these instructions during unit installation in order to enable a Universal® Series 5-ton condenser and air handler split system to operate at 4-ton capacity.

⚠ DO NOT attempt this conversion while the unit is powered on.

1. Locate the capacity dip switch on the condenser main board. The capacity dip switch is circled in the photo below.
2. The default position of the capacity dip switch is 1 & 2 'Up' and 3 & 4 'Down'. Up being a switch pushed toward the letters (ON DIP). Down being a switch pushed toward the numbers (1 2 3 4).
3. The default position of the capacity dip switch is 60K.
4. To activate the 48K capacity, flip capacity dip switch 1 from the Up position to the Down position.

Fig. 2.23

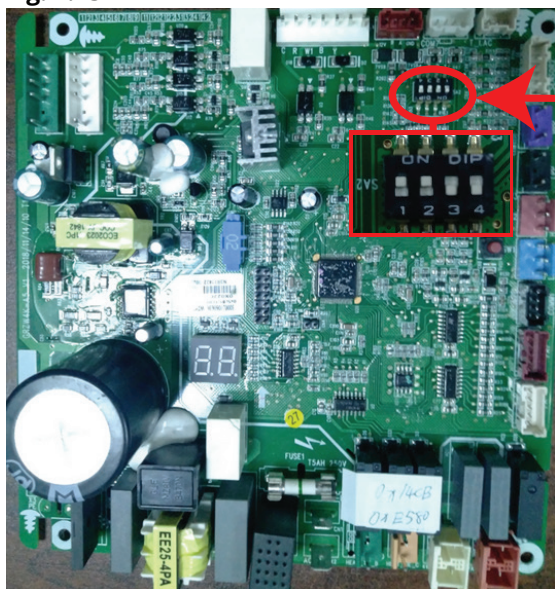

Location of Dip Switch on Condenser Main Board

Fig. 2.25



DEFAULT 5 TON

Fig. 2.26



4 TON SETTING

NOTE

Refer to the Universal Air Handler Installation Manual for Dip Switch Instructions and settings to convert the Universal Air Handler from 3-ton to 2-ton, or 5-ton to 4-ton.

Electrical Connection

Electrical Regulations



WARNING Before performing electrical work, read the following regulations

1. Electrical installation must be conducted only by professionals in compliance with local laws, regulations and this installation manual.
2. Never artificially extend the length of the power cord.
3. The electric circuit must be equipped with a circuit breaker and air switch. Both must have sufficient capacity.
4. Unit operating power must be within the nominal range stated in the instruction manual. Use a specialized power circuit for the air conditioner. ***DO NOT* draw power from another power circuit.**
5. The air conditioner circuit should be at least 5 ft (1.5 m) away from any flammable surface.
6. The external power cord and the thermostat wire must be effectively fixed.
7. The external power cord and the thermostat wire must **NOT** directly contact any hot objects. For example: they must not come into contact with chimney pipes, warm gas pipes, or other heat-producing objects.
8. The external power cord and the thermostat wire must **NOT** be squeezed. Never pull, stretch or bend the wires.
9. The external power cord and the thermostat wire must **NOT** collide with any metal beam or edge on the ceiling, or touch any metal burrs or sharp metal edges.
10. Connect wires correspondingly by referring to the circuit diagram labeled on the unit or electric box. Ensure screws are tightened securely. Slipped screws must be replaced by specialized flat-head screws.
11. The wire gauge of the power cord should be sufficiently large. A damaged power cord or other wires must be replaced by specialized wires. Wiring work must be done according to national wiring rules and regulations.
12. Wiring terminals should be connected firmly to the terminal board.

*****Disclaimer: Wiring must meet code specs according to the capacity/tonnage of the unit.*****

Electrical Connection

Electrical Parameters

Outdoor Unit Model	Power Supply	Fuse Capacity (A)	Max. Overcurrent Protection	Min. Circuit Ampacity
MDUCO18024036	208/230V 1Ph - 60Hz	35 amps	35 amps	24 amps
MDUCO18048060		45 amps	45 amps	35 amps

Connecting the Power Cord & Thermostat Wire



WARNING

1. Before work begins, please check to ensure the unit is powered **OFF**.
2. Improper wire connection may cause electrical components to burn.
3. Connect the wires firmly to the wiring box. Incomplete installation could create a fire hazard.
4. Ground wire must be securely connected.

For solid wires (Refer to Fig. 2.27 A):

1. Use wire cutters to cut off the wire end and then peel away about 1 in (25 mm) of the insulation layer.
2. Use a screwdriver to unscrew the terminal screw on the terminal board.
3. Use nippers to bend the solid wire into a ring that fits the terminal screw.
4. Form a proper ring and then put it on the terminal board. Use a screwdriver to tighten up the terminal screw

For braided wires (Refer to Fig. 2.27 B & Fig. 2.28):

1. Use wire cutters to cut off the wire end and then peel away about 3/8 in (10 mm) of the insulation layer.
2. Use a screwdriver to unscrew the terminal screw on the terminal board.
3. Use a round terminal fastener or clamp to fix the round terminal firmly on the peeled wire end.
4. Locate the round terminal conduit. Use a screwdriver to replace it and tighten up the terminal screw (as shown in Fig. 2.28).

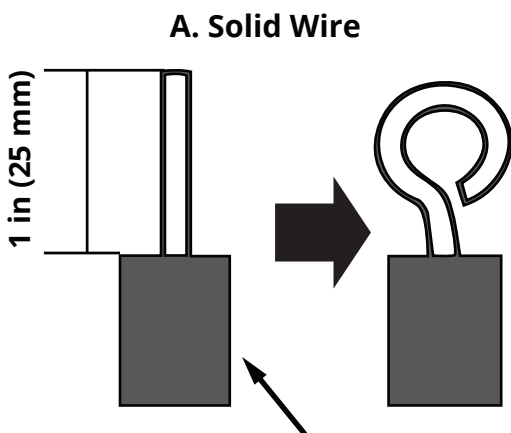

Fig. 2.27 A Insulation Layer

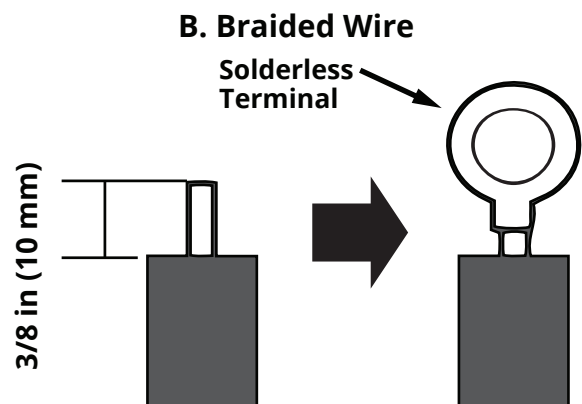

Fig. 2.27 B

Electrical Connection

Connecting the Power Cord & Thermostat Wire

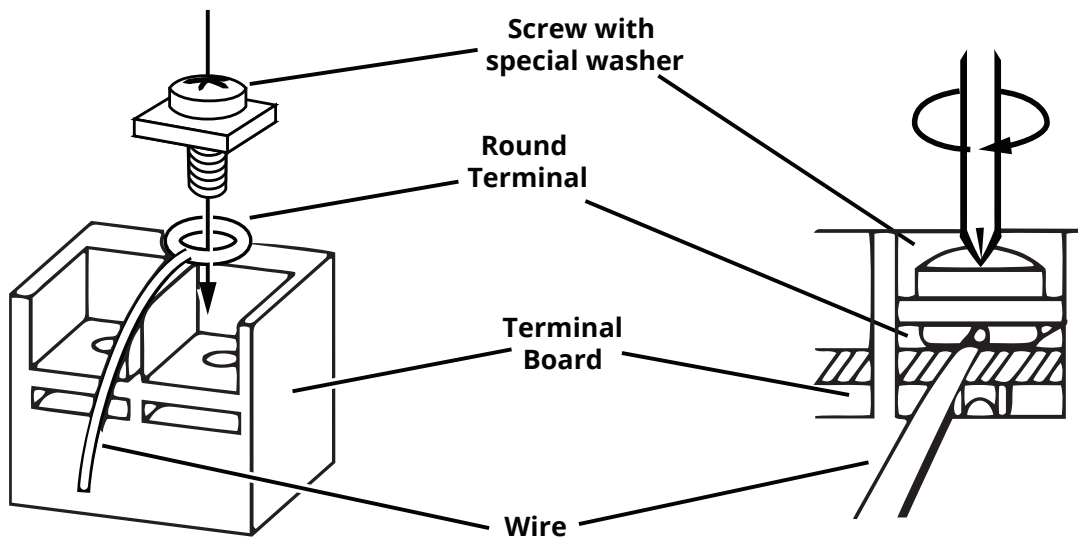

Fig. 2.28

For all terminal wiring (Refer to Fig. 2.29):

5. Lead the thermostat wire and power cord through the insulation tube (as shown in Fig. 2.29).

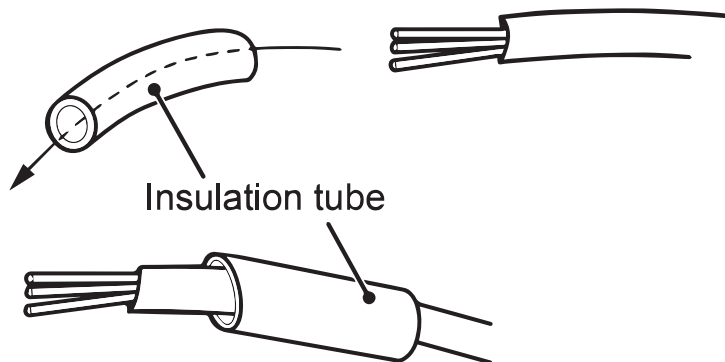

Fig. 2.29

Electrical Connection

Connecting the Power Cord & Thermostat Wire



WARNING

- ⚠ **DO NOT** bundle up the temperature thermostat wires and power wires, or lay them side by side, otherwise errors will occur.
1. High and low voltage wires should be led through different rubber rings of the electric box cover.
 2. High and low voltage wires should be secured separately.
 3. Use screws to tighten the power cord and thermostat wire of the units on the terminal board. An improper connection could create a fire hazard.
 4. If the power cord and thermostat wires are not correctly connected, the air conditioner may suffer damage.
 5. Ground the units through connecting the ground wire and ensure it is secure.
 6. The units should comply with applicable local and national rules and regulations on power consumption.
 7. When connecting the power cord, make sure the phase sequence of the power supply matches with the corresponding terminals, otherwise the compressor will get reversed and operate abnormally.

Electrical wiring of Single-phase unit: MDUCO18024036

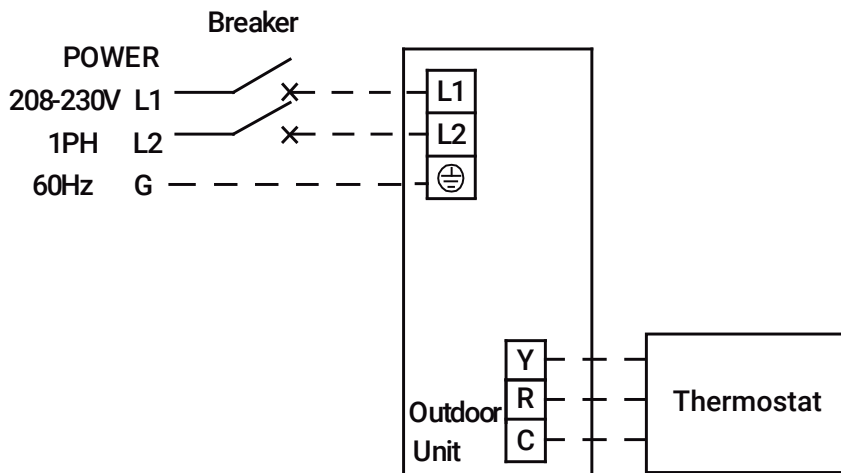

Fig. 2.30-A

Electrical wiring of Single-phase unit: MDUCO18048060

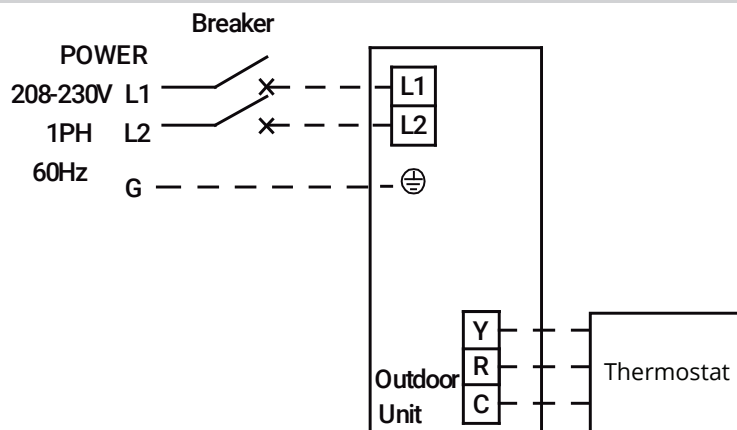

Fig. 2.30-B

Electrical Connection

Connecting the Power Cord & Thermostat Wire

1. Remove the big handle/front panel of the outdoor unit and insert one end of the thermostat wire and the power cord to the terminal board.
2. The power cord should be secured along with the front side plate and fixed to the hook with a wire clamp so as to avoid contacting the pipeline. The temperature thermostat wire should also be laid along with the front side plate but away from the power cord.

Electrical wiring of Single-phase unit: MDUCO18024036

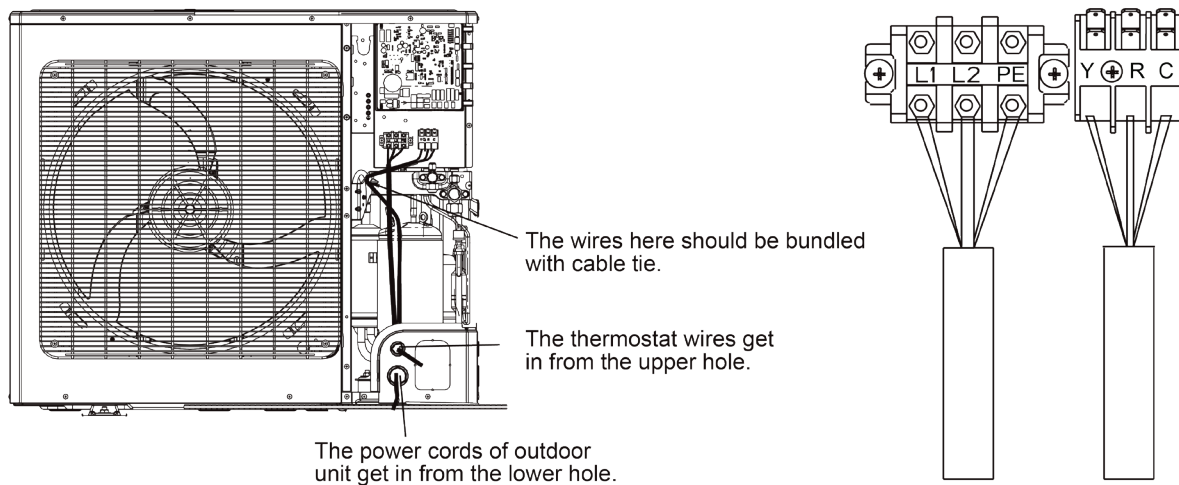

Electrical wiring of Single-phase unit: MDUCO18048060

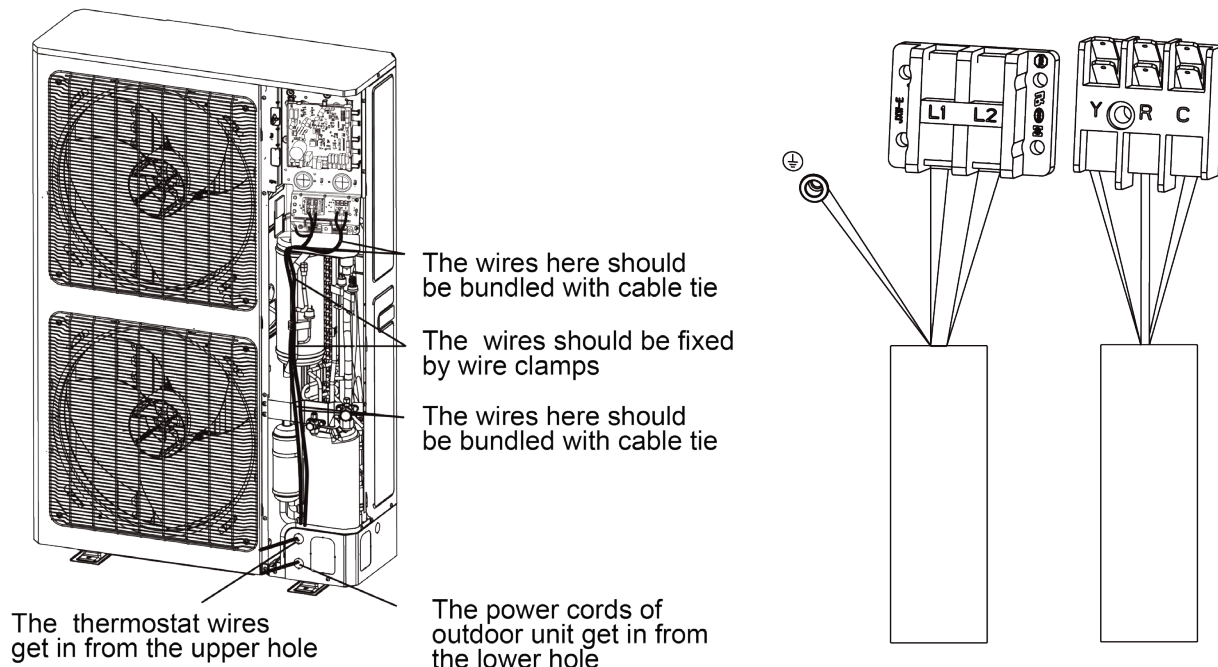

Before Test Run

Only perform test run after you have completed the following steps:

- **Electrical Safety Checks** – Confirm that the electrical system is safe and operating properly.
- **Gas Leak Checks** – Check refrigerant piping connections/valves and confirm the system is not leaking.
- Confirm that gas and liquid (high and low pressure) valves are fully opened.

List of Checks to Perform	Possible Malfunctions	PASS/FAIL	
Is the main body installed securely?	The unit may fall down, vibrate or produce noise.		
Did you conduct a water leakage test?	Cooling capacity may become inadequate.		
Is the unit well insulated from heat?	Condensate/water droplets may occur.		
Does water drain properly from drain hose?	Condensate/water droplets may occur.		
Is the voltage consistent with the specifications stated on the nameplate?	The unit may fail or its components may get burned.	Outdoor (2):	Indoor (2):
Are the wires, piping, and valves installed correctly?	The unit may fail or its components may ignite.		
Has the unit been safely grounded?	Could create a risk of electrical leakage.		
Do the wire specifications comply with the requirements?	The unit may fail or its components may ignite.		
Are there any obstacles blocking the air inlet or outlets of the units?	Cooling capacity may become unsatisfactory.		
Have you recorded the length of refrigerant pipe and the refrigerant charge amount?	The refrigerant charging amount cannot be controlled.		

Test Run

DOUBLE-CHECK PIPE CONNECTIONS

During operation, the pressure of the refrigerant circuit will increase. This may reveal leaks that were not present during your initial leak check. Take time during the Test Run to double-check that all refrigerant pipe connection points do not have leaks.

Test Run Instructions

Preparation before connecting the power:

⚠ **DO NOT connect power unless installation has been fully completed.**

1. Control circuit is correct and all the wires are firmly and securely connected.
2. Stop/Cut-off valves of the gas pipe and liquid pipe are fully opened.
3. The inside of the unit should be clean. Remove irrelevant objects and debris if there are any.
4. After checking, re-install the front side plate.

Operation after connecting the power:

1. If all the steps above have been completed, power on the unit.
2. Make sure the units run normally.
3. If there are any loud and/or abnormal sounds contact MRCOOL® Tech Support immediately, at (270) 366-0457.

NOTICE:

1. If you use the thermostat to turn off the unit and then immediately turn the unit on again, the compressor will need 3 minutes to restart. Even if you press "ON/OFF" button on the thermostat, it will not start up right away. This is to protect the compressor.
2. If there is no display on the temperature thermostat, it is probably because the connection wires between the unit and the temperature thermostat are not connected. Connect them if necessary and recheck the display.

Troubleshooting

(1) If your air conditioner fails to function normally, check the following items before conducting maintenance:

Problem	Cause	Corrective Measure
The air conditioner will not activate.	If you turn off the unit and then immediately turn it on, in order to protect the compressor and avoid system overload, compressor will delay running for 3 minutes.	Please wait for approx. 3 minutes.
	Wire connections are incorrect.	Connect wires according to the wiring diagram.
	Fuse or circuit breaker is broken.	Replace the fuse or switch on the circuit breaker.
	Power failure.	Restart once power is restored.
	Wired connection or power plug is loose.	Re-insert or adjust wires for proper connections to designated terminals.
Inadequate cooling	Air inlet and outlet of the units are blocked.	Clear the obstacles and keep the area well ventilated.
	Improper temperature setting.	Reset to a proper temperature.
	Fan speed is too low.	Reset to a proper fan speed.
	Airflow direction is incorrect.	Change the direction of air louvers.
	Doors and/or windows are open.	Close them.
	Exposed to direct sunlight.	Close curtains or louvers in front of the windows.
	Too many heat sources in the room.	Remove unnecessary heat sources.
	Filter is blocked or dirty.	Replace with a new return filter.
	Air inlet and outlet of the units are blocked.	Clear the obstacles and keep the area well ventilated.

Maintenance

(2) The following situations are not operation failures.

Problem	Time of Occurrence	Cause
Mist comes from the conditioner.	During operation.	If the unit is running under high humidity, the wet air in the room will be quickly cooled down.
The air conditioner generates noise.	The air conditioner is buzzing when operation begins.	Thermostat will be buzzing when it starts working. The noise will become weak 1 minute later.
	When the unit is turned on, it purrs.	When the system has just started, the refrigerant is not stable. About 30 seconds later, the purr of the unit becomes low.
	There is a hissing sound when the unit has been turned on, or stopped suddenly during operation, or after defrosting.	It is the sound of gaseous refrigerant that has stopped flowing or changed direction, and the sound of the drainage system.
	There is a crunching sound during and after operation.	Because of temperature change, the front panel and other components may swell and cause an abrasive sound.
Dust comes from the air conditioner.	The unit starts operation after being unused for a long time.	Dust from inside the units is dispersed with the supply airflow.
The air conditioner generates smells.	During operation.	Smells from the operating environment may be pulled through the air handler and dispersed throughout the rooms.

NOTICE

Check the above items and take appropriate corrective measures. If the air conditioner continues to improperly function, please turn off the air conditioner immediately and contact MRCOOL® Tech Support, at (270) 366-0457, or your installing dealer.

Error Code

WARNING

- When abnormalities occur, stop the unit immediately and disconnect power. Contact MRCOOL® Tech Support, at (270) 366-0457. If the unit continues to run abnormally, it may damage the unit and cause an electric shock and/or a fire hazard.
- ⚠ ***DO NOT*** attempt repairs to the appliance yourself. Improper repair and maintenance can create electric shock and/or fire hazards. Please contact MRCOOL Tech Support, at the phone number above, for further guidance or a qualified professional for repairs.

If the LED display panel on the main board of the outdoor unit displays an error code, please refer to the following table:

Number	Error Code	Error
1	E1	Compressor high pressure protection
2	E3	Compressor low pressure protection
3	E4	Compressor air discharge high-temperature protection
4	F2	Condenser temperature sensor error
5	F3	Outdoor ambient temperature sensor error
6	F4	Discharge temperature sensor error
7	F6	Outdoor unit tube temperature sensor error
8	EE	Outdoor unit memory chip error
9	H4	Overload
10	H5	IPM protection
11	H6	DC fan error
12	H7	Driver out-of-step protection
13	HC	Pfc protection
14	Lc	Startup failure
15	P0	Drive reset protection
16	P5	Over-current protection
17	p6	Master control and driver communication error
18	P7	Driver module sensor error
19	P8	Driver module high temperature protection
20	PA	AC current protection
21	Pc	Driver current error

Number	Error Code	Error
22	PL	Bus low-voltage protection
23	PH	Bus high-voltage protection
24	PU	Charge loop error
25	ee	Driver memory chip error
26	e3	Low pressure sensor error
27	C4	ODU jumper cap error

Unit Maintenance

Warning

- 1) Only professionals may carry out annual maintenance.
- 2) Before contacting any wire, make sure power is turned off.
- 3) Do not allow flammable objects near the unit.
- 4) Do not use organic solvent to clean the air conditioner.
- 5) If you need to replace a component, contact a professional to repair the unit with a component supplied by MRCOOL® to ensure the quality.
- 6) Improper operation may damage the unit, causing electric shock or fire.
- 7) Do not immerse the air conditioner in water or electric shock could occur. Also, do not use water to rinse the unit during cleaning.

Warning

- 1) Before cleaning, ensure the power is off. Turn off at circuit breaker and remove the disconnect, to avoid electric shock.
- 2) Do not wash the air conditioner with water, otherwise fire and/or electric shock may occur.
- 3) Use care when cleaning the filter.
- 4) If you need to work from an elevated position (such as on a ladder), please exercise caution.

Unit Maintenance

Outdoor Heat Exchanger

Clean the heat exchanger on the outdoor unit, at least once every two months. Remove the dust and debris on the surface of the heat exchanger with a dust collector and nylon brush. If there is a compressed air source; use the compressed air to gently blow the dust off the surface of the heat exchanger.

⚠ ***DO NOT*** use tap water for cleaning.

Condensate Drain

Periodically check if the condensate drain is blocked to avoid condensate backing up into the system, as this could cause property damage and/or the unit to fail.

Pre-Season Inspection Check List

1. Check for blockages in the air inlet/outlet.
2. Check the ground connection and make sure it is still securely connected.
3. Check that the air filter screen is properly installed and clean.
4. If starting up the unit after a long period of inactivity, flip the power switch of the air conditioner to “**ON**” status at least 8 hours prior to operation. This is to preheat the crankcase on the compressor.
5. Check that the outdoor unit is firmly secured.
6. If problems are detected, contact your local service professional or MRCOOL® Tech Support, at (270) 366-0457.

Post-Season Maintenance Check List

1. Deactivate the main power to the air conditioner;
2. Remove dust and debris from the outdoor unit;
3. If the outdoor unit is rusty, paint the location with anti-rust paint to prevent it from continuing to spread.

Component Replacement

Components are available from MRCOOL® and associated dealers.

Notice on Maintenance

Service Information

The manual contains specific information for service personnel who will perform maintenance on the product.

General Work Area

Inform others working in the immediate vicinity about the nature of work being performed. Avoid working in confined spaces. Section off the area around the workspace. Ensure conditions within the area are safe by removing potentially flammable material.

Ventilated Area

Ensure the area is adequately ventilated before opening the system or conducting any refrigerant work. Maintain adequate ventilation while working. Effective ventilation will safely disperse any released refrigerant into the atmosphere.

Refrigeration Equipment Checks

Ensure all electrical components are compatible with the product and built to the correct specifications. Follow manufacturer maintenance and service guidelines at all times. When in doubt, consult the MRCOOL® Technical Department, at (270) 366-0457, for further assistance.

If using flammable refrigerants, conduct the following checks:

1. Ensure ventilation machinery and outlets are operating adequately and are not obstructed.
2. If an indirect refrigerating circuit is being used, check the secondary circuit for the presence of refrigerant.
3. Check that equipment markings are visible and legible. Replace markings that are illegible.
4. Ensure refrigeration piping or components are installed in a position where they are unlikely to be exposed to any substance which could corrode refrigerant containing components, unless the components are constructed of materials which are inherently resistant to being corroded, or are suitably protected against corrosion.

Electrical Device Checks

Electrical component repair and maintenance should include initial safety checks and component inspection procedures.

- ⚠ ***DO NOT* connect the circuit to an electrical supply if a fault exists that could compromise safety. The fault must be corrected.**

Notice on Maintenance

Electrical Device Checks (cont.)

Initial safety checks should include:

1. Safe discharge of capacitors to avoid the possibility of sparking.
2. No live electrical components and wiring should be exposed while charging, recovering, or purging the system.
3. The system is safely grounded.

Sealed Component Repairs

ELECTRICAL SAFETY

Ensure that this system is installed using a disconnect box that meets national, state, and local electrical and HVAC code requirements. The location of the disconnect box(es), number of disconnect boxes needed, and distance from the unit(s) to the disconnect box(es) should be handled in accordance with national, state, and local electrical and HVAC code. Also ensure that there is a permanent form of leak detection, at the most critical point to warn of a potentially hazardous situation.

ATTENTION

- Electrical component casings should not be altered in such a way that the level of protection is affected. This includes damage to cables, excessive number of connections, terminals not made to original specification, damage to seals, incorrect fitting of glands, etc.
- Ensure the apparatus is securely mounted.
- Ensure the seals or sealing materials have not degraded in such a way that they no longer serve the purpose of preventing the ingress of flammable atmospheres.
- Replacement parts should be in accordance with manufacturer specifications.

NOTICE

- The use of silicon sealant may inhibit the effectiveness of some types of leak detection equipment.
- Intrinsically safe components do not have to be isolated prior to working on them.

Intrinsically Safe Component Repair

⚠ DO NOT apply any permanent inductive or capacitance loads to the circuit without first ensuring that this will not exceed the permissible voltage and current permitted for the equipment in use.

1. Intrinsically safe components are the only types that can be worked on while live in the presence of a flammable atmosphere. The test apparatus must be at the correct rating.
2. Replace components only with parts specified by the manufacturer. Other parts may result in the ignition of refrigerant in the atmosphere from a leak.

Notice on Maintenance

Cabling

Check that cabling will not be subject to wear, corrosion, excessive pressure, vibration, sharp edges, or any other adverse environmental effects. The check should also take into account the effects of aging or continual vibration from sources such as compressors or fans.

Charging Procedures

In addition to conventional charging procedures, the following parameters must be followed:

1. Ensure refrigerant contamination does not occur when charging equipment.
2. Hoses or lines should be as short as possible to minimize the refrigerant contained in them.
3. Cylinders must be kept upright.
4. Ensure that the system is securely and properly grounded prior to charging the system with refrigerant.
5. Take extreme care to avoid refrigerant overfill.
6. Label the system when charging is complete (if not already).
7. Extreme care shall be taken not to overfill the refrigeration system.
8. Prior to recharging the system pressure test with OFN. The system must be leak tested when charging is complete and prior to commissioning. A follow up leak test must be carried out before leaving the site.

Decommissioning

Before decommissioning, it is essential that the technician become completely familiar with all of the equipment in detail. It is recommended, and good practice, that all refrigerants be recovered safely. Before decommissioning, an oil and refrigerant sample should be taken. This is in case an analysis is required prior to the re-use of the reclaimed refrigerant. It is essential that electrical power is available before the task is commenced.

Before decommissioning procedure, ensure the following:

1. You are familiar with the equipment and its operation.
2. The system has been isolated electrically.
3. Mechanical handling equipment is available, if required, for handling refrigerant cylinders.
4. All personal protective equipment is available and being used correctly.
5. The recovery process is supervised at all times by a competent person.
6. Recovery equipment and cylinders conform to the appropriate standards.

Decommissioning procedure:

1. Pump down refrigerant system, if possible.
2. If a vacuum is not possible, make a manifold so that refrigerant can be removed from various parts of the system.
3. Make sure that cylinder is situated on the scales before recovery takes place.
4. Start the recovery machine and operate in accordance with manufacturer's instructions.

⚠ ***DO NOT* overfill cylinders. Cylinders should have no more than an 80% volume of liquid charge.**

Notice on Maintenance

Decommissioning (cont.)

⚠ ***DO NOT* exceed the maximum working pressure of the cylinder, even temporarily.**

6. When the cylinders have been filled correctly and the process completed, ensure the cylinders and the equipment are removed from site promptly and all isolation valves on the equipment are closed.
7. Recovered refrigerant must not be charged into another refrigeration system until it has been cleaned and checked.

Labeling

Equipment should be labeled to state that it has been decommissioned and emptied of refrigerant. The label must be dated and signed.

Recovery

When removing refrigerant from a system, either for servicing or decommissioning, it is a recommended, and always a good practice, that all refrigerants are removed safely.

When transferring refrigerant into cylinders, ensure that only appropriate refrigerant recovery cylinders are employed. Ensure that the correct number of cylinders for holding the total system charge are available. Ensure that all cylinders to be used are designated for the recovered refrigerant and labeled for that refrigerant. Cylinders should be complete with pressure relief valve and associated shut-off valves in good working order.

In addition, a set of calibrated weighing scales should be available and in good working order. Hoses shall be complete with leak-free disconnect couplings and in good condition. Before using the recovery machine, check that it is in satisfactory working order and has been properly maintained. Consult the manufacturer if in doubt.

The recovered refrigerant should be returned to the refrigerant supplier in the correct recovery cylinder, and the relevant Waste Transfer Notice arranged.

⚠ ***DO NOT* mix refrigerants in recovery units and especially not in cylinders.**

If compressors or compressor oils are to be removed, ensure that they have been evacuated to an acceptable level to make certain that flammable refrigerant does not remain within the lubricant. The evacuation process shall be carried out prior to returning the compressor to the suppliers. Only electric heating to the compressor body should be employed to accelerate this process. When oil is drained from a system, it should be carried out safely.

After-Sales Services

Any quality or other issues encountered in the purchased air conditioner, please contact the local MRCOOL® after-sales service department.

This appliance contains refrigerant and other potentially hazardous materials. When disposing of this appliance, the law requires special collection and treatment.

⊘ ***DO NOT* dispose of this product as household waste or unsorted municipal waste.**

When disposing of this appliance, you have the following options:

- Dispose of the appliance at a designated municipal electronic waste collection facility.
- When buying a new appliance, the retailer will receive the old appliance free of charge.
- The manufacturer will receive the old appliance free of charge.
- Sell the appliance to certified scrap metal dealers.

Special notice

Disposing of this appliance in the forest or other natural surroundings endangers your health and is bad for the environment. Hazardous substances may leak into the ground water and enter the food chain.

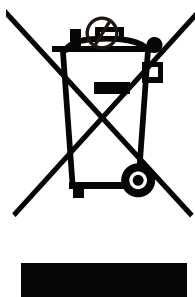



MRCOOL®

COMFORT MADE SIMPLE

Universal® Series

ELECTRICIAN and/or HVAC TECHNICIAN:

LICENSE #:

INSTALLATION DATE:

INSTALLATION LOCATION:

SERIAL NUMBER: